



HSL-Series

Heavy-Lifting Strand Jack System

World Class Strand Jacks

- Precision Control
- Durability
- Reliability
- Safety



▼ Shown: HSL50006 Strand Jack



- Precision control of synchronous lifting and lowering
- Can be controlled by a single operator from a central location for increased safety
- Automated locking - unlocking operation
- Two strand sizes: 15,7 mm and 18 mm (.62 and .71 inch)
- Telescopic strand guide pipes prevent bird caging
- Internal components are coated with Lunac, an anti-corrosion coating, making it suitable for marine environments
- Lifting anchor included with all strand jacks
- Lloyd's witness tested to 125% of maximum working load



Heavy-Lifting Strand Jacks

High Capacity
Precision Control



Strand Jacks

Enerpac strand jacks are the strand jacks of choice for customers seeking precise synchronous control with heavy-lifting capacity in an economical, compact, and reliable foot print.

Enerpac strand jacks are powered by electrical or diesel driven hydraulic power packs and controlled by Enerpac's proprietary SCC-Smart Cylinder Control System to ensure full control of lifting and lowering operations.

Enerpac continually improves reliability, durability, and safety of their strand jacks, making them an industry standard for heavy-lifting.



Strand Wedges

Wedges are hardened and nickel coated to resist corrosion, resulting in an extra long life.

Page:  7

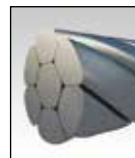

Heavy-Lifting Strand

Enerpac offers 15,7 mm (.62 inch) and 18 mm (.71 inch) heavy duty strands.

Page:  7

◀ HSL85007 Strand Jack System used on Enerpac custom Self Erecting Tower.

Heavy-Lifting Strand Jacks



Strand Jacks

A strand jack can be considered a linear winch. In a strand jack, a bundle of steel strands are guided through a main "lifting" jack.

Above and below the cylinder are anchor systems with wedges that grip the strand bundle simultaneously. Lifting and lowering a load is achieved by hydraulically controlling the main jack and both mini jacks alternately.

In the case of system pressure loss, the wedges are mechanically closed automatically, holding the suspended load in place.

Today strand jacks are widely recognized as the most sophisticated heavy lifting solution. They are used all over the world to erect bridges, load out offshore structures, and lift/lower heavy loads where the use of conventional cranes is neither economical nor practical.

HSL Series



Capacity:
15 - 1250 ton

Stroke:
250 - 600 mm

Maximum Operating Pressure:
350 bar

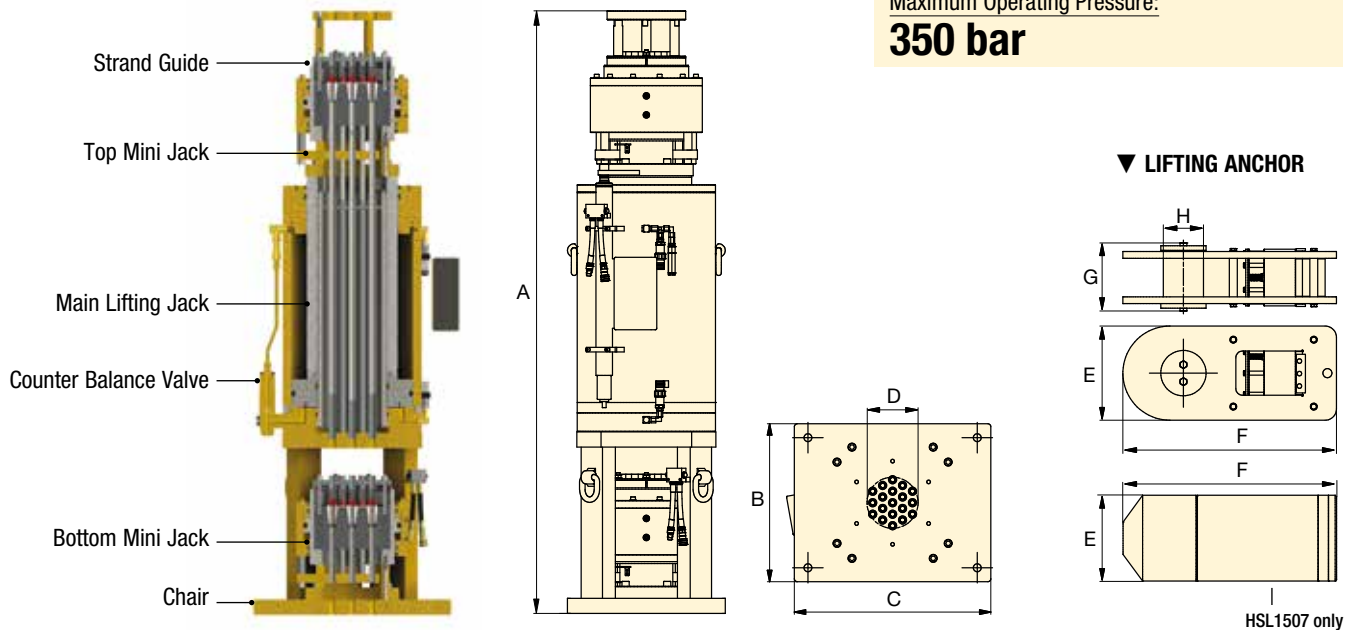

STRAND JACKS										LIFTING ANCHORS (included)					
Strand Diameter mm (inch)	Capacity *		Model Number	Number of Strands	Stroke (mm)	A (mm)	B (mm)	C (mm)	D (mm)	🏋️ (kg)	E	F	G	H	🏋️
	ton	(kN)									(mm)	(mm)	(mm)	(mm)	(kg)
15,7 (.62)	30	(300)	HSL3006	3	480	1851	350	500	59	500	180	695	162	90	40
	70	(700)	HSL7006	7	480	1915	360	575	93	640	250	721	130	110	60
	200	(2000)	HSL20006	19	480	1992	522	650	169	1300	415	942	300	177	260
	300	(3000)	HSL30006	31	480	2046	673	673	216	2180	490	1145	340	195	380
	500	(5000)	HSL50006	48	480	2136	733	733	273	3150	620	1385	410	245	750
18 (.71)	15	(150)	HSL1507	1	250	1242	220	220	20	100	65	162	-	-	5
	45	(450)	HSL4507	3	480	1728	350	500	73	500	190	715	216	80	50
	60	(600)	HSL6007	4	480	1752	400	625	88	650	250	716	192	120	60
	100	(1000)	HSL10007	7	480	1926	408	625	116	850	300	840	188	120	110
	200	(2000)	HSL20007	12	480	2001	522	650	165	1400	415	942	300	177	260
	300	(3000)	HSL30007	19	480	2055	673	673	210	2180	490	1145	340	195	380
	450	(4500)	HSL45007	31	480	2223	733	733	272	3050	620	1385	422	245	700
	650	(6500)	HSL65007	43	480	2237	850	850	351	3950	710	1550	523	285	1190
	850	(8500)	HSL85007	55	480	2402	900	900	364	5000	785	1730	549	315	1520
	1000	(10.000)	HSL100007	66	480	2558	1092	1092	436	7650	780	2045	683	380	2650
	1250	(12.500)	HSL125007	84	600	2658	1100	1100	458	8300	-	-	-	-	-

* Capacity is based on 2,5 minimum safety factor over strand breaking load. See page 7 for details.

SCC-Smart Cylinder Control System

▼ Shown: SCC-Smart Cylinder Control System



Smart Box

The Smart Box is Enerpac's proprietary control platform. It allows an operator to control up to 60 strand jacks simultaneously with a standard laptop.

Smart Box Model number
Optional Laptop Model nr

SBSJSCC-V4
SBLT-1.

- Single operator control from a central location provides safe and reliable operation
- Synchronous lift/lower and load control between the lifting positions
- Automatic lifting and lowering cycles
- Displays individual and accumulative stroke/load
- Ability to operate up to 60 strand jacks simultaneously
- Simple graphical user interface
- Data logging and export capabilities.

▼ Enerpac's SCC-Smart Cylinder Control System simplifies synchronous operation with intuitive controls and a user-friendly graphical interface.



▼ System overview showing a 2-Point Lift with Automatic Control

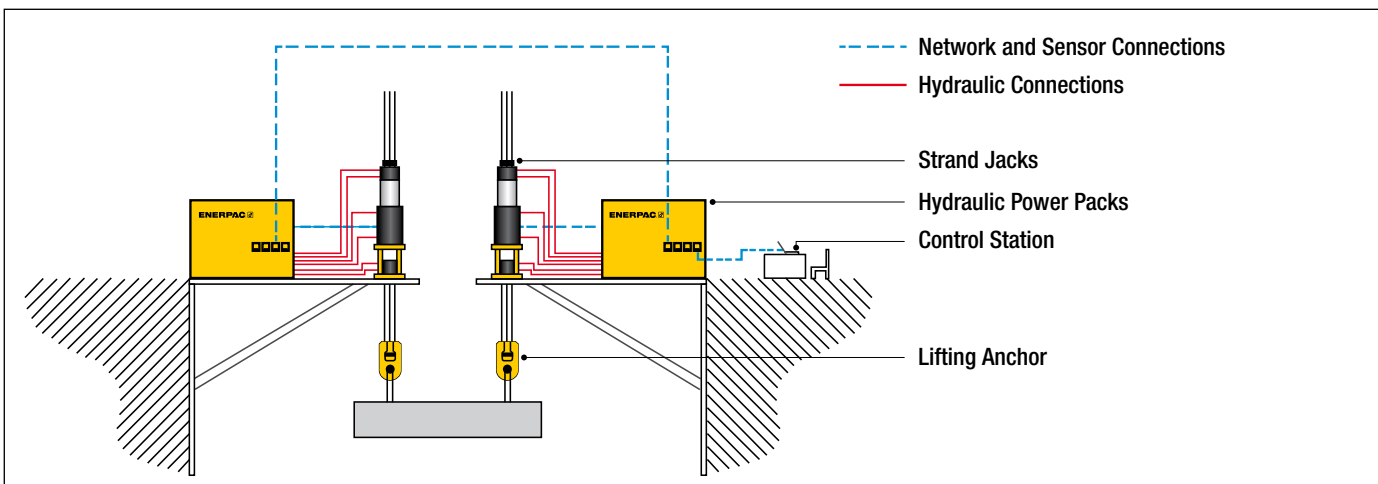

SLPP-Series, Hydraulic Power Packs

▼ Shown: SLPP55E Hydraulic Power Pack



Reservoir Capacity:

20 - 350 litres

Flow at Rate Pressure:

10 - 100 l/min

Motor Size:

2,2 - 55 kW

Maximum Operating Pressure:

350 bar



Hydraulic Power Packs

Enerpac offers a comprehensive range of hydraulic power packs that are optimized for use with their industry leading strand jacks.

- Variable frequency drive motor for precision control
- Optimized for use with specific strand jack sizes
- Equipped with a hydraulic safety circuit
- Pumps are easily connected with a standard RS-485 network cable
- Integrated E-stop on pump
- Connection for auxiliary hand pendant
- Pumps include:
 - Reservoir sight glass
 - Return tank filter
- Enclosed frame with integrated lifting lugs and fork lift pockets
- Standard voltage for electric pumps is 480V, 50/60Hz, 3-phase (other voltages available upon request).

Strand Jack Capacity (ton)	Theoretical Lifting Speed (m/hr) *							
	Motor Size (kW) *							
	2,2	5,5	7,5	15	18,5	30	37	55
15	16	-	-	-	-	-	-	-
30	12	13	16	-	-	-	-	-
45	12	13	16	-	-	-	-	-
60	9	10	13	-	-	-	-	-
70	9	10	13	-	-	-	-	-
100	8	9	11	16	-	-	-	-
200	-	-	6	10	12	15	15	-
300	-	-	-	7	8	11	11	-
450	-	-	-	6	7	10	10	-
500	-	-	-	6	7	10	10	-
650	-	-	-	-	-	8	8	15

* Theoretical lifting speeds. Each application should be evaluated to determine the optimum lifting speed for maximum safety and control. Contact Enerpac for more information.

Motor Size (kW)	Model Number	Motor Type	Oil Flow (l/min)	A (mm)	B (mm)	C (mm)	Weight (kg)
2,2	SLPP2E	Electric	10	832	600	600	150
5,5	SLPP5E	Electric	12	968	600	754	190
7,5	SLPP7E	Electric	16	968	600	750	190
15	SLPP15E	Electric	27 - 40	1389	1000	1000	600
18,5	SLPP18E	Electric	40 - 58	1540	1100	1100	1036
30	SLPP30E	Electric	46	1285	1700	900	1250
37	SLPP37D	Diesel	46	1285	1700	880	1250
55	SLPP55E	Electric	100	2070	2200	1100	2100

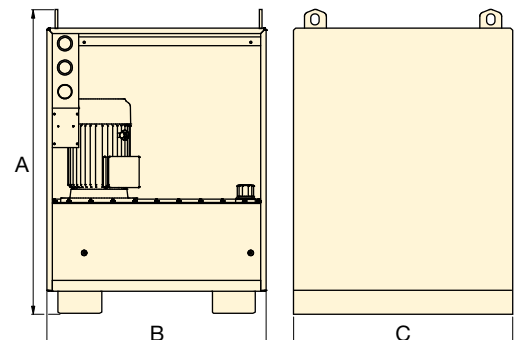



Strand Guide

- Provides a guide for the strand as a strand jack lifts the load
- Capable of feeding the strands into a strand recoiler
- Adjustable height.

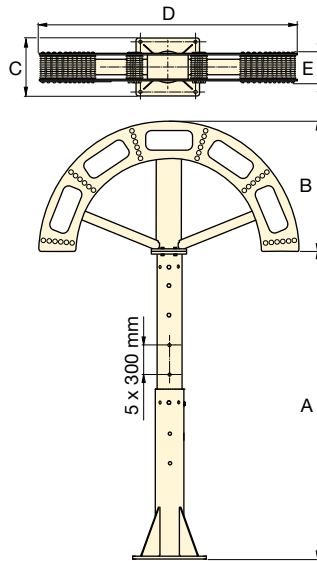

Optional Strand Tensioner

Enerpac's Strand Tensioner System simplifies strand jack setup, when used with large strand jacks.

Strand Tensioners attach to the top of a strand jack and ensure all strands have even load distribution. The tensioning cycle is automatically controlled by Enerpac's SCC Software.

Model Number	Maximum Number of Strands		A (mm)		B (mm)	C (mm)	D (mm)	E (mm)	 (kg)
	15,7 mm (.62 inch)	18 mm (.71 inch)	min.	max.					
SGS1	19	13	2760	4260	950	600	1900	210	450
SGM1	48	48	2069	3569	1125	600	2249	342	700
SGL1	55	55	2500	4000	1530	750	3060	375	1300



Strand Recoiler

- Passively pays in or pays out strands while jacking and lowering
- Must be used in combination with an Enerpac strand guide.

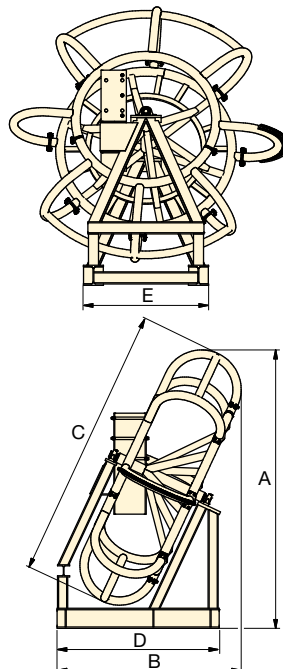

Transporting Strand Jacks

Enerpac offers custom transportation crates for each Strand Jack.

Each custom crate is tailored to a specific Strand Jack and Anchor. These crates provide a secure and safe method for easily transporting any Enerpac Strand Jack.

Model Number	Max. Number of Strands	Strand Capacity (length in meters)		A (mm)	B (mm)	C (mm)	D (mm)	E (mm)	 (kg)
		15,7 mm (.62 inch)	18 mm (.71 inch)						
SRCS1	20	750	500	1930	1000	1762	1000	1800	445
SRCL1	48	6000	4000	2756	1831	2706	1605	1240	1000

HSL-Series, Strand Jack Accessories

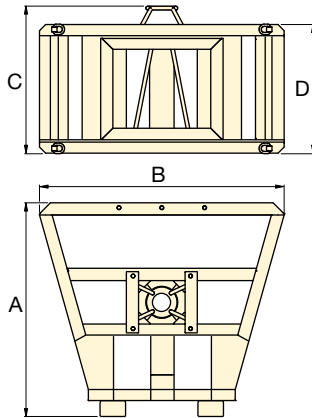

Strand Dispenser

- Essential to safely unbundle a new strand coil
- Provides method for dispensing strand for set-up

Model Number	A	B	C	D	
	(mm)	(mm)	(mm)	(mm)	(kg)
SD1	1745	2000	1205	1050	650



Strand Wedges

- Specially designed for superior performance with Enerpac strand jacks
- Three-piece wedge design with a friction grip profile on the inside of each piece
- Hardened nickel coated wedges for long life and trouble free wedge release
- Wedges are included with every strand jack purchase and available as spare parts.

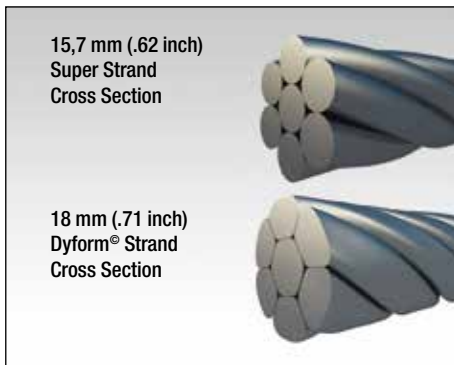

Heavy-Lifting Strand

- Strands available in 15,7 mm Super or 18 mm Dyform®
- Strand jack and strand combinations are designed to meet a minimum 2,5 x safety factor to working load
- Constructed of seven twisted, high-capacity steel wires.

Model Number	For Strand Diameter		Package Quantity
	(mm)	(inch)	
HLW06	15,7	0.62	50
HLW07	18	0.71	50



Wedge Lubricant

During wedge maintenance or wedge replacement, it is critical that the outside of the wedges are thoroughly lubricated before placing them back into the anchor block. A stick lubricant or another type of pressure resistance grease should be used.

Model number **22601005**.

Strand Diameter	Strand Type	Model Number *	Tensile Strength	Steel Area	Breaking Load	Length per Coil	Mass	
mm (inch)			(N/mm ²)	(mm ²)	(kN)	(m)	(kg/m)	(kg)
15,7 (.62)	Super	SC06	1860	150	279	2560	1,17	3000
18 (.71)	Dyform®	SC07	1700	223	380	1720	1,74	3000

* Sold by the coil.

HSL-Series, Heavy-Lifting Strand Jacks



The Industrial Tools Line

Cylinders and Lifting Products

- General Purpose
- Aluminium Lightweight
- Pancake
- Flat-Jac®, Low Height
- Pull
- Hollow Plunger
- Precision
- Long Stroke
- High Tonnage
- POWR'RISER® Lifting Jacks
- Jacks
- Cylinder-Pump Sets

Pumps

- Manual
- Cordless & Electric Driven
- Compressed Air Driven
- Petrol Driven

System Components

- Hoses, Couplers, Oil
- Gauges, Adaptors
- Manifolds, Fittings

Valves

- 3-and 4-Way Directional
- Pressure and Flow Control

Presses

- Bench, Workshop, Roll Frame
- Arbor and C-Clamps
- Tension Meters, Load Cells

Pullers

- Master Pullers Sets
- Multi Purpose Puller Sets
- Posi Lock® Pullers

Tools

- Maintenance Sets
- Punches
- Machine Lifts
- Lifting Wedge
- Load Skates
- Cutters
- Pipe Benders
- Wedgie, Spreaders

Bolting Tools

- Multipliers
- Torque Wrenches
- Impact Sockets
- Bolt Tensioners
- Wrench and Tensioner Pumps
- Flange Alignment Tools
- Flange Facing Tool
- Nut Splitters

Enerpac Service Van

Enerpac Worldwide Locations

For a complete list of addresses see:
www.enerpac.com/en/contact-us

About Enerpac

Enerpac is the leading global provider of high-pressure hydraulic tools and solutions with a broad range of products, local expertise and worldwide distribution network. With a proven track record in a wide range of markets, Enerpac designs and manufactures high-quality tools and solutions for all industrial applications.

Enerpac has gained unique experience in delivering hydraulic solutions for the controlled movement and positioning of heavy objects. Enerpac supports your business by offering the right solutions and service to help you get your work done efficiently and safely.

www.enerpac.com

- Online Bolting Calculator
- Learn more about hydraulics
- Promotions
- New products
- Electronic Catalogues
- Trade Shows
- Manuals (instruction and repair sheets)
- Nearest Distributors & Service Centers
- Enerpac products in action
- Integrated Solutions.

Ordering Products and Catalogues

To find the name of the closest Enerpac distributor or service center, to request literature or technical application assistance, contact Enerpac at one of the addresses on www.enerpac.com or pose your question through E-mail: info@enerpac.com



Hydraulic solutions for controlled movement and positioning of heavy loads

While Enerpac has the world's largest product portfolio for heavy-lifting and load-control applications, we also have the knowledge to put all these programs together or modify them to provide a lift system for your most demanding and unique applications.

- Synchronous Lifting Systems
- Jack Up Systems
- Bridge Launching Systems
- Synchronous Hoisting Systems
- Hydraulic Gantries
- Heavy-Lifting Strand Jacks
- Skidding Systems
- Self-Erecting Towers
- Chain Pulling Systems
- Self-Propelled Modular Transporter

Your Enerpac Distributor: