

PA-Series, Air Hydraulic Foot Pumps

▼ Shown: PA-1150, PA-133



PA Series

Reservoir Capacity:
0,6 - 1,3 litres

Flow at Rated Pressure:
0,13 l/min

Air Consumption:
255 l/min

Maximum Operating Pressure:
700 bar



Reservoir Conversion Kit

Double the reservoir capacity of your existing PA-133 with this easy to install conversion kit.

Model Number

PC-66

- Rugged construction – built for long life and easy service
- Swivel coupling simplifies hydraulic connection and pump operation
- Three-position treadle provides cylinder advance, hold or retract operation
- Operates in all positions for increased versatility in use and mounting (except PA-1150)
- Base mounting slots provided on PA-133.

OIL FLOW VERSUS PRESSURE

at 6,9 bar air pressure

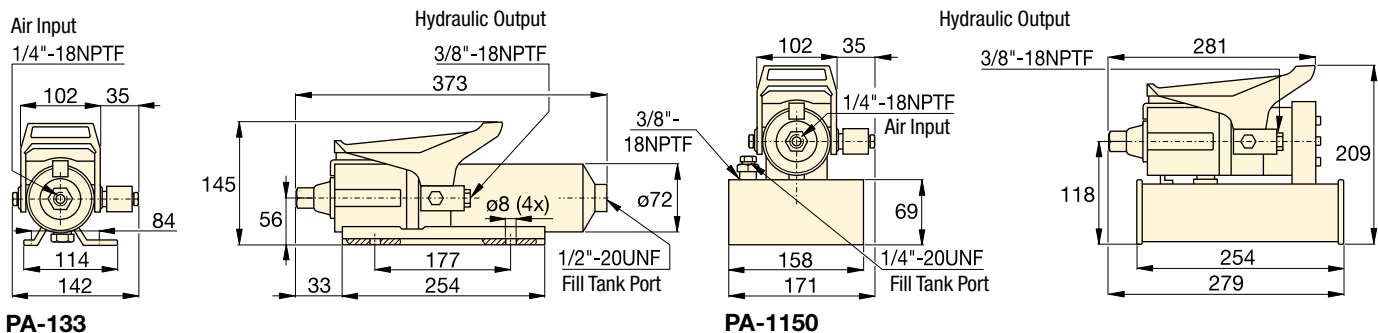
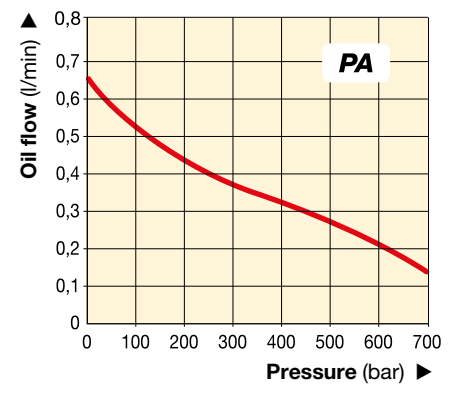

Used with Cylinder	Usable Oil Capacity (cm ³)	Model Number	Pressure Rating (bar)	Output Flow Rate (l/min)		Valve Function	Air Pressure Range * (bar)	Air Consumption (l/min)	Sound Level (dBA)	Weight (kg)
				No load	Load					
Single-Acting	589	PA-133	700	0,65	0,13	Advance / Hold / Retract	4,1 - 8,3	255	85	5,4
	1311	PA-1150	700	0,65	0,13	Advance / Hold / Retract	4,1 - 8,3	255	85	8,2

* Recommended Regulator-Filter-Lubricator: RFL-102.