

▼ Shown: **XA11G**



- Ergonomic design for less operator fatigue
- Variable oil flow & fine metering for precise control
- Higher oil flow for increased productivity
- Closed hydraulic system prevents contamination and allows pump usage in any position
- Pedal lock function for retract position
- Ground screw for improved ATEX explosion safety
- External adjustable pressure setting valve.

▼ Easy operated by foot. No need to fully lift up foot – rest bodyweight on heel, resulting in a handsfree and stable working position.



XVARI[®] TECHNOLOGY

Productivity & Ergonomics



Optional Pressure Gauge

Integrated gauge with calibrated scale reading in bar, psi and MPa for actual pressure reading.



4/3 Control Valve

For powering double-acting hydraulic cylinders and tools.



2 Litres Reservoir

Double oil capacity for powering larger hydraulic cylinders and tools.



Pedal Safety Guard

Customer installed frame protects both pedals against accidental activation.

Model Number ¹⁾

XPG1



"Joy-stick" Lever Kit

Customer installed set of handles for manual operation of both pedals.

Model Number ¹⁾

XLK1



Swivel Connector

Customer installed swivel connector for optimal orientation of the hydraulic hose.

Model Number ¹⁾

XSC1

¹⁾ Accessories must be ordered separately.

XVARI® Technology, Air Driven Hydraulic Foot Pumps



XVARI® Technology Production Application

XA11 pump is used with a 13 tons hollow cylinder to compress and position diesel engine valve springs. The operator benefits from the fine metering capacities of the XVARI® Technology to apply the mandatory precise stroke and force.

www.xvari.com

XA Series

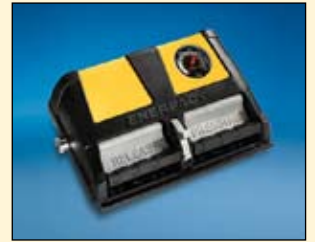

Reservoir Capacity:
1,0 - 2,0 litres

Flow at Rated Pressure:
0,25 l/min

Air Consumption:
283 - 991 l/min

Maximum Operating Pressure:
700 bar

▼ XA-SERIES PERFORMANCE CHART

Maximum Pressure (bar)	Output Flow Rate (l/min)		Pump Series	Valve Function	Dynamic Air Pressure (bar)
	No load	Load			
700	2,0	0,25	XA1	Advance/Hold/Retract	2,1 - 8,6

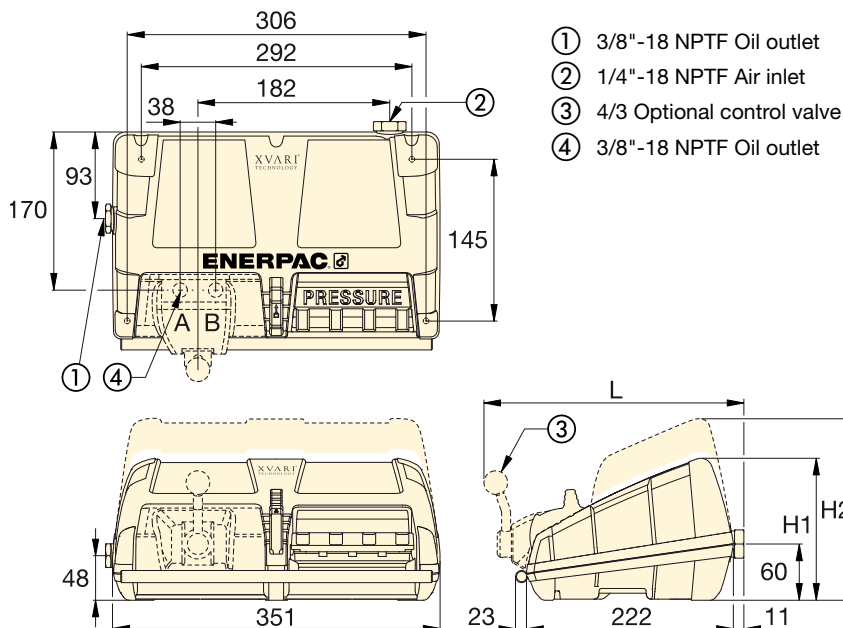

OIL FLOW VERSUS PRESSURE

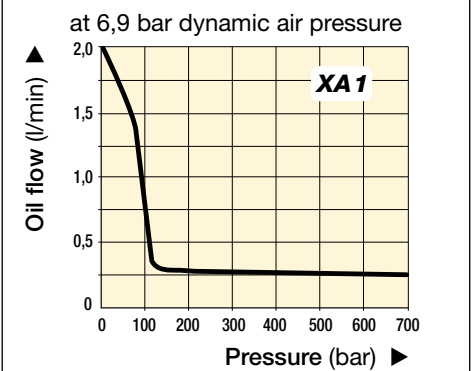

Regulator-Filter-Lubricator

Recommended for use with all XA-Series Air pumps. Provides clean, lubricated air and allows for air pressure adjustment.

Model Number **RFL102**

▼ SELECTION CHART

For use with cylinder or tool	Usable Oil Capacity (litres)	Model Number ¹⁾	Pressure Gauge	3-way 3-pos. Valve	4-way 3-pos. Valve	Dimensions (mm)			(kg)
						H1	H2	L	
Single-acting	1,0	XA 11 ²⁾	–	•	–	152	–	–	8,6
	2,0	XA 12 ²⁾	–	•	–	–	170	–	10,2
Single-acting	1,0	XA 11G	•	•	–	152	–	–	8,8
	2,0	XA 12G	•	•	–	–	170	–	10,4
Double-acting	1,0	XA 11V	–	–	•	152	–	279	10,1
	2,0	XA 12V	–	–	•	–	170	279	11,7
Double-acting	1,0	XA 11VG	•	–	•	152	–	279	10,3
	2,0	XA 12VG	•	–	•	–	170	279	11,9

¹⁾ High-Flow coupler CR-400 and accessories must be ordered separately.

²⁾ Available as cylinder-pump set, see page 62.