

▼ Shown from left to right: ZG6440MX-BFCH, ZG5420MX-B



Z Tough,
Dependable,
Innovative
CLASS

- Features Z-Class high efficiency pump design, higher oil flow and bypass pressure
- Two-speed operation reduces cycle time for improved productivity
- User adjustable relief valve built-in on manual valves. Oil ports on valves are 3/8" NPTF
- Available in three 4-cycle engine sizes: 4,1 kW Honda and 4,8 kW and 9,7 kW Briggs & Stratton
- Full sight oil level glass on all reservoirs allow quick and easy oil level monitoring.

ZG6-Series

- Easy serviceable 9,7 kW, 4-cycle gasoline engine with electric start, pressurized oil and 12 Volt charge output for accessories
- Dual forced air heat exchanger stabilizes hydraulic oil temperature
- Sturdy wheeled cart with collapsible handles.



GA45GC Gauge Adaptor Assembly

Protect yourself from system overloading by simply ordering one part number for a pre-assembled gauge, adaptor block and coupler.

Page: 142



User Adjustable Relief Valve

All VM-Series directional valves have a user adjustable relief valve to allow the operator to easily set the optimum working pressure.

Page: 122

▼ SELECTION CHART

Used with Cylinder	Reservoir Size (litres)	Manual Valve ¹⁾ Model Number	Valve Function	Model Number with Roll Cage	Output Flow Rate (l/min)				4-Cycle Engine Type and Size
					at 7 bar	at 50 bar	at 350 bar	at 700 bar	
Single-Acting	9,8	VM33	Advance / Hold / Retract	ZG5310MX-R	11,5	10,7	1,8	1,6	Honda 4,1 kW
	19,8	VM33	Advance / Hold / Retract	ZG5320MX-R	11,5	10,7	1,8	1,6	
Double-Acting	9,8	VM43	Advance / Hold / Retract	ZG5410MX-R	11,5	10,7	1,8	1,6	
	19,8	VM43	Advance / Hold / Retract	ZG5420MX-R	11,5	10,7	1,8	1,6	
Single-Acting	9,8	VM33	Advance / Hold / Retract	ZG5310MX-BR	6,5	6,2	1,8	1,6	Briggs & Stratton 4,8 kW
	19,8	VM33	Advance / Hold / Retract	ZG5320MX-BR	6,5	6,2	1,8	1,6	
Double-Acting	9,8	VM43	Advance / Hold / Retract	ZG5410MX-BR	6,5	6,2	1,8	1,6	
	19,8	VM43	Advance / Hold / Retract	ZG5420MX-BR	6,5	6,2	1,8	1,6	
	39	VM43L	Advance / Hold / Retract	ZG5840MX-BR	6,5	6,2	1,8	1,6	
Double-Acting	39	VM43	Advance / Hold / Retract	ZG6440MX-BCFH	14,7	14,5	3,7	3,3	
	–	–	–	–	–	–	–	–	

¹⁾ See pages 122-123 for hydraulic symbols of these valves.



ZG-Series, Gasoline Pump Performance

Elevation can affect the performance of any gasoline engine. ZG-Series pumps are designed to develop rated performance at elevations up to 1500 m. For applications above this elevation, please consult your Enerpac office.

Optional: Diesel Engine

ZG-Series pumps can also be equipped with a Diesel Engine. Contact Enerpac for details.

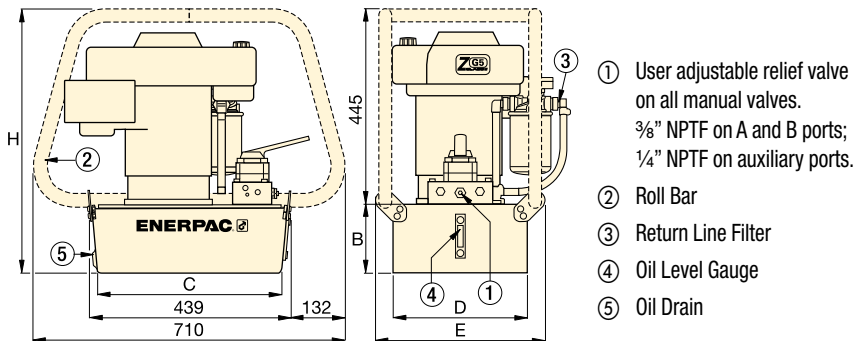

ZG5-Series

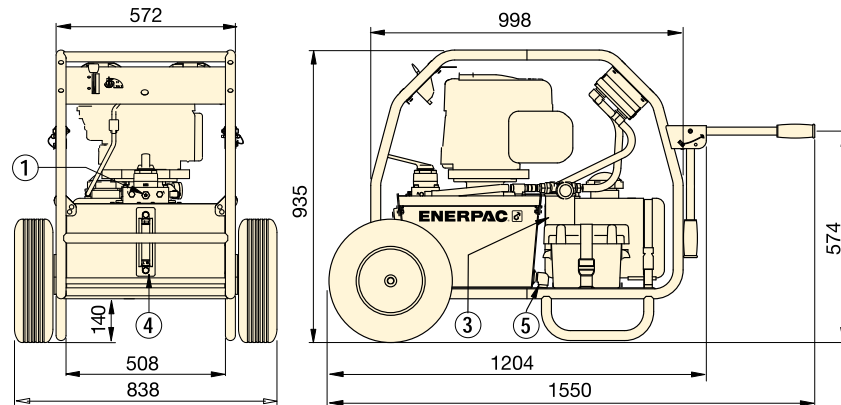

ZG6-Series

ZG Series



Reservoir Capacity:

9,8 - 19,8 - 39 litres

Flow at Rated Pressure:

1,6 - 3,3 l/min

Engine Size:

4,1 - 4,8 - 9,7 kW

Maximum Operating Pressure:

700 bar



High Pressure Hoses

Enerpac offers a complete line of high quality hydraulic hoses. To ensure the integrity of your system, specify only genuine Enerpac hydraulic hoses.

Page: 128



Speed Chart

To determine how a specific pump will operate your cylinder, see the Pump-Cylinder Speed Chart in the 'Yellow Pages'.

Page: 405

Relief Valve Adjustment Range (bar)	Sound Level (dBA)	Dimensions (mm)					Model Number with Roll Cage (kg)	
		B	C	D	E	H		
70 - 700	88 - 93	155	419	305	384	600	52	ZG5310MX-R
		180	414	421	500	625	64	ZG5320MX-R
		155	419	305	384	600	52	ZG5410MX-R
		180	414	421	500	625	64	ZG5420MX-R
70 - 700	88 - 93	155	419	305	384	600	50	ZG5310MX-BR
		180	414	421	500	625	63	ZG5320MX-BR
		155	419	305	384	600	50	ZG5410MX-BR
		180	414	421	500	625	63	ZG5420MX-BR
		269	399	505	557	714	86	ZG5840MX-BR
70 - 700	88 - 93	-	-	-	-	-	152	ZG6440MX-BCFH
		-	-	-	-	-	-	-

OIL FLOW VERSUS PRESSURE

