

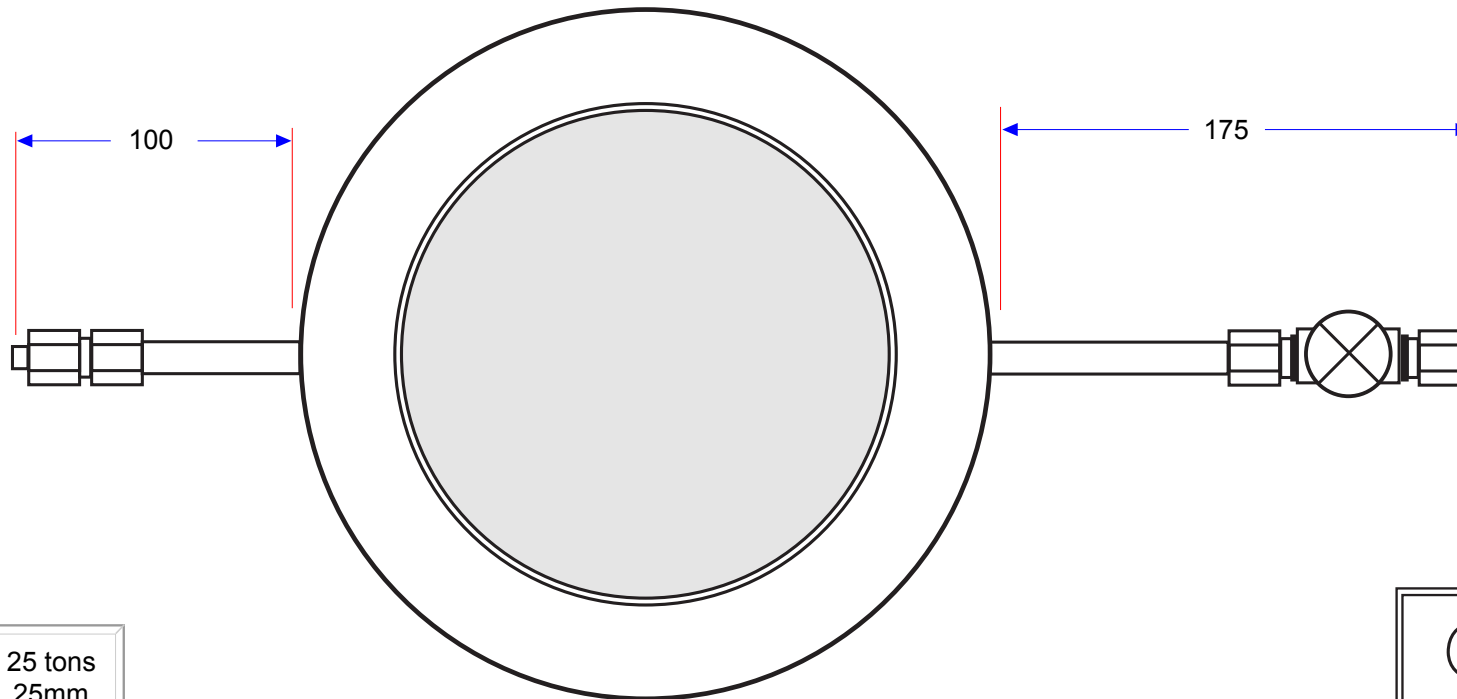

FJ19 Flat Jack

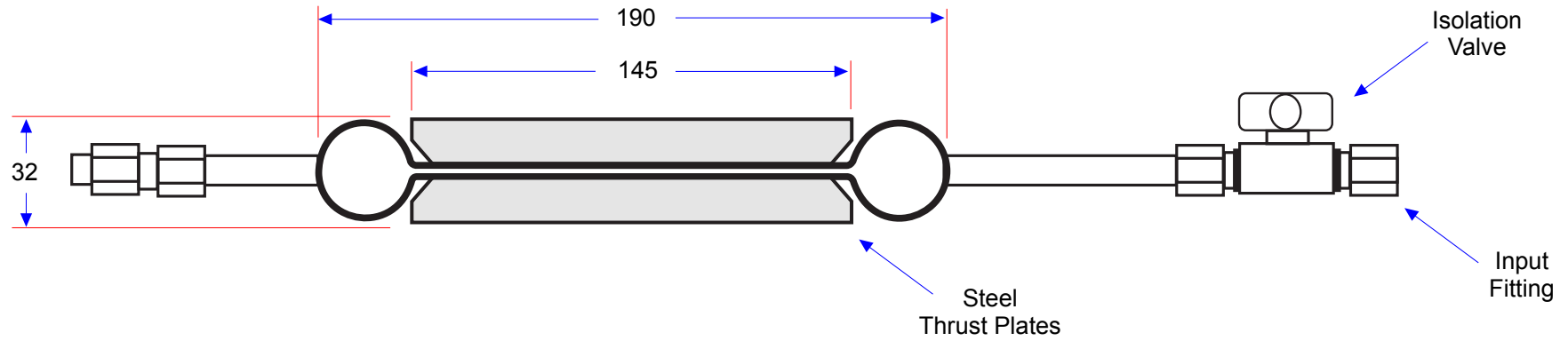

Maximum Capacity: 25 tons
Maximum Stroke: 25mm
Maximum Pressure: 150 bar
Fluid Requirement: 1.1 Lts
Jack Weight: 10.0 Kgs

| | |
|---|-----------------------|
|  HYDRA-CAPSULE HEAVY DUTY JACKING SYSTEMS | |
| DESCRIPTION: | FJ-19 Flat-Jack |
| DRAWING No. | Xara / FJ-19 / 2007-A |