

WASHING

Direct Drive Roller Drier

Produce drying system



Effective for removing surface
moisture from produce

We treasure your roots



TECHNICAL DATA

(20 Row 1200mm wide model)

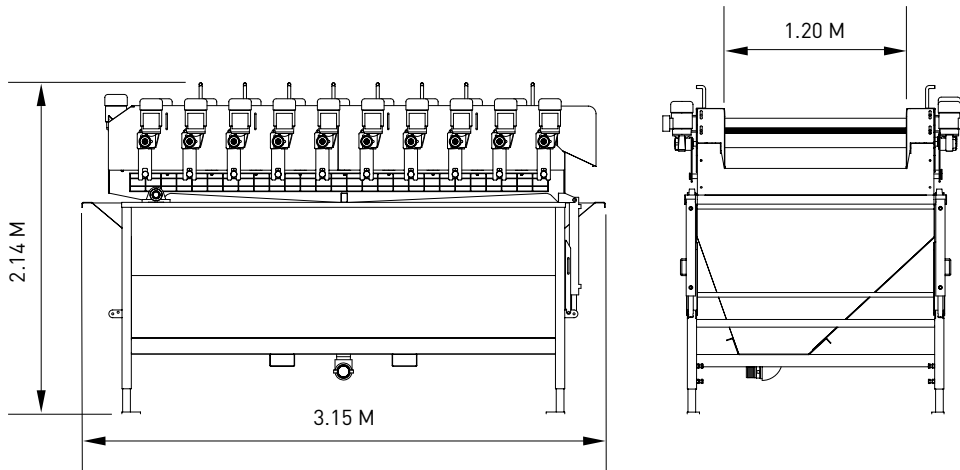

Efficient produce drying system with easy clean access

FEATURES

- Wrapped felt or sponge disc roller options
- Direct drive to each roller with no chains or sprockets, reduces overall maintenance
- Catchment tank for waste water and debris
- Soft start system for all rollers with motors wired to a central control panel
- Pintle roller for initial de-watering
- Stainless steel contact sides for low maintenance and easy clean
- Rollers can be replaced simply and quickly
- Hydraulic lift mechanism gives easy access for maintenance and cleaning

OPTIONS

- Full stainless steel construction
- 900mm, 1200mm and 1500mm widths available
- 15 or 20 roller lengths available depending on drying requirements
- Brush roller configurations for stone removal
- Motorised crop clearance system
- Special models available for bespoke drying applications

RANGE OF MODELS

- 900mm wide
- 1200mm wide
- 1500mm wide

SPECIFICATION

Roller Motors:
 Individual roller drive motor
 0.25kw complete with
 Harting plug connector

Herbert B.V. | Luchthavenweg 99
 NL-5657 EA Eindhoven | The Netherlands
 tel. +31(0) 40 20 10 434
 info@herbertsolutions.com

www.herbertsolutions.com

DESIGN > BUILD > INSTALL > SUPPORT



Cleaning



Grading



Conveying



Tipping



Washing



Sorting



End of line



Service & Parts