

WASHING

Pre-Soak Tank

Pre-wash to loosen soil prior to de-stoning or washing



A water hopper which prevents damage when receiving product and gives an initial cleaning/soaking action prior to delivery to the rest of the processing line.



TECHNICAL DATA

(Elevator 4.5M x 800mm Stainless Steel)

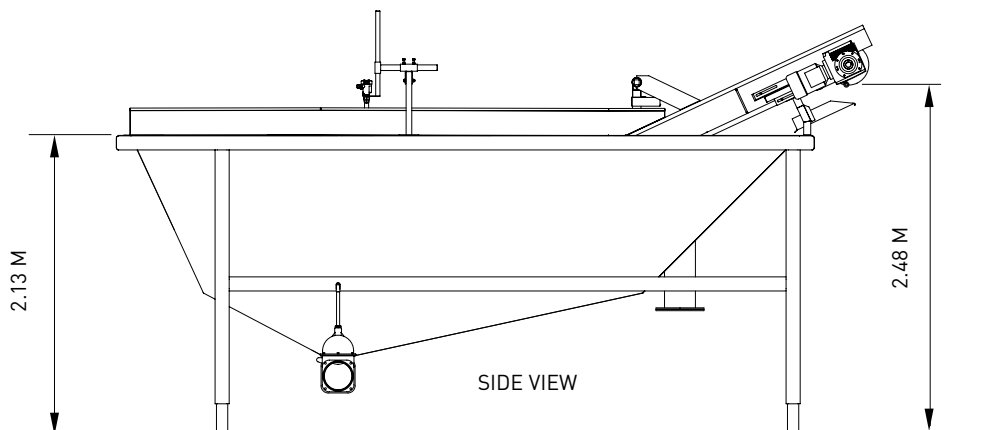
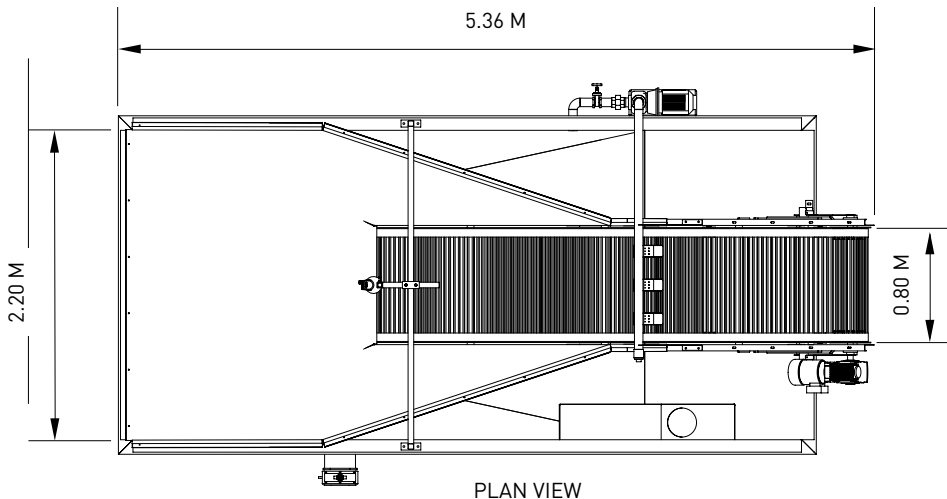

RANGE OF MODELS

- 900mm infeed
- 1800mm infeed

SPECIFICATION

Holding Capacity of a Standard Tank:
2.6 tonnes

Pump:
Submersible 4.7kw

Crop Sensors:
Ultrasonic

Water Level Indicator:
Float switch

Elevator Motor:
1.5kw 18rpm

Elevator Web Belt:
35mm pitch x 800mm w
web complete with plast
covers with 7-8mm gap

Power Supply:
32A 6 pole

Simple and efficient pre-soaking for a range of crops

FEATURES

- Both mild and stainless steel construction available
- A range of capacities from 5TPH to 40TPH
- Simple gate valve for waste water discharge
- Web delivery elevator to drain excess water
- Integrated spray bar for fresh or recycled water rinse
- Electronic variable speed drive to control flow rate
- Ultrasonic sensing system to prevent overfeed

Herbert B.V. | Luchthavenweg 99
NL-5657 EA Eindhoven | The Netherlands
tel. +31(0) 40 20 10 434
info@herbertsolutions.com

www.herbertsolutions.com

DESIGN > BUILD > INSTALL > SUPPORT



Cleaning



Grading



Conveying



Tipping



Washing



Sorting



End of line



Service
& Parts