

Retain views, daylighting & ventilation



When the Sun overheats your home
NOTHING beats KoolShade.

Index

Screen Datasheet	03
KoolShade Screen Weights	04
Transportation	05
Returns policy	05
Terms & Conditions	06

For further details, specification, construction and installation information, please visit our website:

 smartlouvre.com/technical-datasheets-drawings

 smartlouvre.com/fixing-options

Screens Datasheet

Frame options:

Various to suit application

Thickness of fabric:

1.5mm coated

Weft width:

1.25mm coated

Louvre pitch:

1.5mm centre to centre

Weft thickness:

0.30mm coated

Gap between each louvre:

1.20mm coated

Warp spacing:

12.70mm centre to centre

Clear open area:

80%

Openness factor:

67%

Screen weight:

3-4 kg/m² dependent on frame option/size

Frame composition:

Extrusions - Aluminium EN AW6063 T6

Lacer Wire - 316 Stainless Steel

Anti-Vibration Wedge - Ceramic Thermal Break - to suit application

Fabric composition:

90% CuZn15 (C230) commercial bronze and 10% CUSi3Mn1 (C655) silicon bronze

Finishes:

Polyester powder coat in any RAL colour (with the ability to create designs on the fabric which are directionally visible)

Fire rating:

Class A1/A2-s1,d0 in accordance with BS EN 13501- 1:2007+A1:2009

Fire attenuation:

49.4% | Compliant screening for bushfire up to BAL-40 (based on 40kW/m² incident irradiance)

Resistance to wind:

Hurricane proof: 100mph/160kph

Wind load:

<14.65 kgf/m²



A result of decades of extensive international research and development, MicroLouvre is a high-performance, woven metal fabric, with its weft constructed of bronze louvres.

Window covering screens are constructed by tensioning the fabric in aluminium framing and incorporate an anti-vibration wedge to enhance the screen's integrity at wind speeds in excess of 100mph/160kph.

The micro-fine louvres are angled to suit a number of applications, whether to ensure optimum light in, and visibility out, whilst blocking heat and glare or, to allow ventilation and even protect from external viewing in.

It's known as angular selective technology.

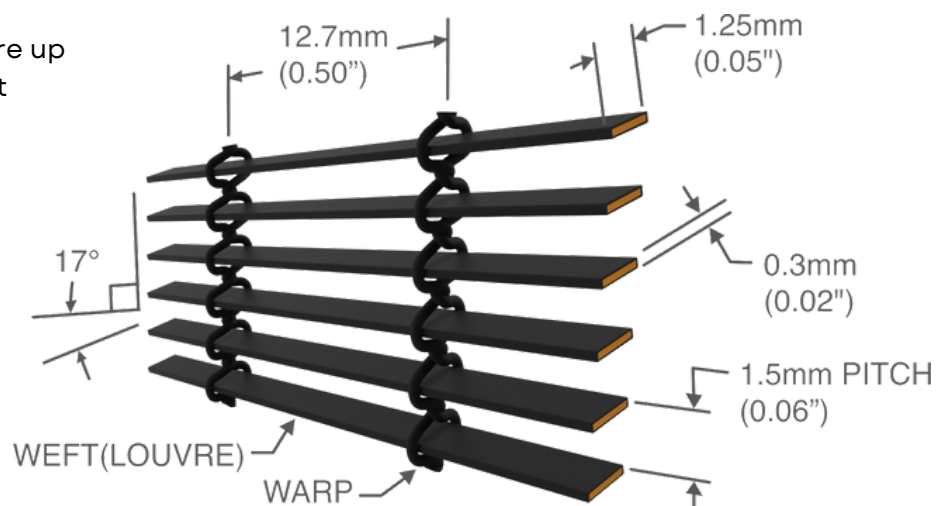

All angles, weights and dims are nominal

Visit us:

www.smartlouvre.com

Talk to us:

+44 (0) 239 245 6333

Request a sample:

info@smartlouvre.com

KoolShade® Screen Weights

K-700 Painted SCREEN WEIGHTS IN KILOGRAMS (KG)

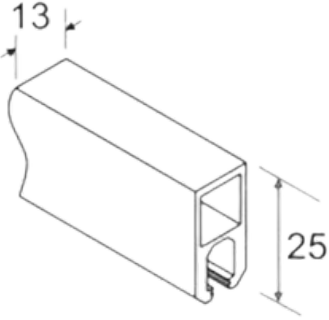

FE25

DROP

	WIDTH				
	400mm	600mm	800mm	1000mm	1200mm
400mm	0.92	1.18	1.44	1.70	1.97
600mm	1.19	1.50	1.81	2.12	2.43
800mm	1.46	1.82	2.17	2.53	2.89
1000mm	1.73	2.13	2.54	2.94	3.35
1200mm	1.99	2.45	2.90	3.36	3.81
1400mm	2.26	2.76	3.27	3.77	4.27
1600mm	2.53	3.08	3.63	4.18	4.73
1800mm	2.80	3.40	3.99	4.59	5.19

Screens of these sizes require care when hinged. Please refer to SmartLouvre for advice.

Vertical Sliding
Overlapping

TRACKS

DT34 + DT34
0.38
0.58
0.77
0.96
1.15
1.34
1.54
1.73

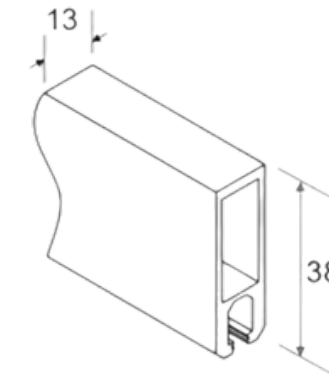

FE38

DROP

	WIDTH						
	400mm	600mm	800mm	1000mm	1200mm	1400mm	1600mm
400mm	1.12	1.42	1.73	2.04	2.34	2.65	2.96
600mm	1.43	1.79	2.14	2.50	2.85	3.21	3.56
800mm	1.74	2.15	2.55	2.96	3.36	3.76	4.17
1000mm	2.06	2.51	2.96	3.42	3.87	4.32	4.77
1200mm	2.37	2.87	3.37	3.87	4.38	4.88	5.38
1400mm	2.69	3.24	3.78	4.33	4.88	5.43	5.98
1600mm	3.00	3.60	4.20	4.79	5.39	5.99	6.59
1800mm	3.31	3.96	4.61	5.25	5.90	6.54	7.19
2000mm	3.63	4.32	5.02	5.71	6.41	7.10	7.79
2200mm	3.94	4.69	5.43	6.17	6.91	7.66	
2400mm	4.26	5.05	5.84	6.63	7.42	8.21	

Screens of these sizes require care when hinged. Please refer to SmartLouvre for advice.

TRACKS

DT34 + DT34
0.38
0.58
0.77
0.96
1.15
1.34
1.54
1.73
1.92
2.11
2.30

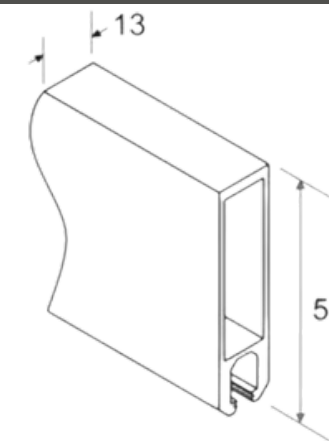

FE51

DROP

	WIDTH							
	400mm	600mm	800mm	1000mm	1200mm	1400mm	1600mm	1800mm
400mm	1.40	1.76	2.11	2.47	2.82	3.18	3.53	3.89
600mm	1.77	2.17	2.57	2.98	3.38	3.78	4.19	4.59
800mm	2.13	2.58	3.03	3.48	3.94	4.39	4.84	5.29
1000mm	2.49	2.99	3.49	3.99	4.49	4.99	5.49	5.99
1200mm	2.85	3.40	3.95	4.50	5.05	5.60	6.14	6.69
1400mm	3.21	3.81	4.41	5.01	5.60	6.20	6.80	7.39
1600mm	3.58	4.22	4.87	5.51	6.16	6.80	7.45	8.09
1800mm	3.94	4.63	5.33	6.02	6.71	7.41	8.10	8.80
2000mm	4.30	5.04	5.78	6.53	7.27	8.01	8.75	9.50
2200mm	4.66	5.45	6.24	7.03	7.83	8.62	9.41	10.20
2400mm	5.02	5.86	6.70	7.54	8.38	9.22	10.06	10.90
2600mm	5.39	6.27	7.16	8.05	8.94	9.82	10.71	11.60
2800mm	5.75	6.68	7.62	8.56	9.49	10.43	11.36	12.30
3000mm	6.11	7.09	8.08	9.06	10.05	11.03	12.02	13.00

TRACKS

DT34 + DT34
0.38
0.58
0.77
0.96
1.15
1.34
1.54
1.73
1.92
2.11
2.30
2.50
2.69
2.88

TRACKS

CODE	WIDTH	400mm	600mm	800mm	1000mm	1200mm	1400mm	1600mm	1800mm
DT34 + BT32	Lift in/Lift out	0.31	0.47	0.62	0.78	0.94	1.09	1.25	1.40
RT37 + DT34	Lateral Sliding	0.46	0.70	0.93	1.16	1.39	1.62	1.86	2.09

Transport & Returns Policy

Transport

Orders over £750 will be delivered to the UK mainland free of charge.

Orders under £750 will be transported by our preferred courier company. A quote specific to the order quantities, sizes and weights will be communicated with the buyer and agreed to before dispatch. Collection by the buyer can be arranged either in person or via a 3rd Party by contacting info@smartlouvre.com or by calling 0239 245 6333

Returns Policy

We offer a 30-day return policy for private retail customers. If you change your mind once you have received your goods, you must return the goods to us, complete, in the original packaging and a resalable condition.

This includes pallet deliveries, any items that arrive on a pallet must be returned on the same pallet. We will refund your transaction less the carriage costs incurred by our company in delivering the goods.

You must call us on 0239 245 6333 before returning any goods, to confirm the address where the goods are to be returned.

Goods must be returned within 7 working days of agreeing on the return and include your sales documentation.

Where faulty Goods have been supplied the Seller will offer a replacement or full refund including the cost of delivery and returning the Goods.

Where the Buyer changes their mind and wishes to return the Goods the Seller must be informed within 30 days of delivery and the Goods returned to an address specified by the Seller.

It is the Buyers responsibility to ensure that returned Goods reach us in re-sellable condition. They should be packed well in the original packaging and will be inspected before any refund can be issued. The refund will be the purchase price less the carriage costs incurred by the Seller.

Bespoke Orders. Built Order Confirmation (B.O.C) will be sent where products are built to the customer dimensions and specifications. These are NOT REFUNDABLE.



DEFINITIONS

In these conditions "the Company" means the company named overleaf or above. "Goods" mean such products as may be manufactured and/or supplied by the Company pursuant to the Contract herein and shall, where the context so admits include any part of the Goods. "Buyer" means the person, Firm or company which whom the Contract is made. "Order" means the Order placed by the Buyer for the supply of the Goods. "Quotation" means such quotation as may have been provided by the Company referring to the Goods supplied under the Contract. "Quotation Form" means the Quotation Form in the standard form for the time being issued by the Company. "Contract" means the formal agreement between the Buyer and the Company.

FORMATION AND SCOPE OF CONTRACT

- (i). A Quotation whether or not contained in a Quotation Form is not an offer and shall be no binding Contract until the order has been issued by the Buyer to the Company.
- (ii). The Contract is subject to these conditions and (subject to clause 3 hereof), shall not be entered into until the order has been issued in writing by the Buyer. No variation waiver or addition expressed or implied to these conditions shall be binding on the Company or the Buyer except as specifically agreed by both parties in writing.
- (iii). In so far as the Buyer purports to incorporate in an order any items inconsistent with these conditions, these conditions shall prevail and the Contract shall be deemed to be made on terms excluding the Buyers in consistent terms unless the said term shall have been specifically agreed by the Company in writing referring expressly to the said term incorporated by the Buyer.

PRICES

Prices are quoted exclusive of Value Added Tax unless specifically stated. The Company reserves the right to vary the price of the Goods by notice to the Buyer given at any time before delivery for and to the extent that there is any increase in the price or cost of the goods to the Company by reason of any foreign exchange fluctuations, changes in currency regulations, alterations in duties, variations in Goods or raw materials, increase in the cost of materials, wages, overheads, transport or by any reasonable cause, (whether or not of the same nature as the forging) beyond the control of the Company.

INSTALLMENTS

Where delivery of the goods is to be made by instalments, each delivery shall be deemed to be and treated as a separate Contract but the failure of any delivery shall not violate the Contract as to the other delivery. Payment of any sum on the due date is a condition precedent to future deliveries.

TERMS OF PAYMENT

- (i). All payments are due without any deduction whatsoever.
- (ii). Unless otherwise specifically agreed in writing between the Company and the Buyer payment for the Goods shall be made prior to despatch.
- (iii). All payments shall be made in the currency stated in the Contract, or, if no currency is specifically stated, then in sterling payable at the Company's Head Office shown overleaf or at the Company's Bank in the United Kingdom. All bank charges for the transfer of payment to the United Kingdom shall be for the Buyer's account.
- (iv). If any sum payable by the Buyer hereunder is not paid within fourteen, (14) days after having fallen due, interest shall be payable by the Buyer on the amount of the unpaid sum at the rate of 8 percent (8%) per annum above Bank of England Base Rate from time to time calculated on a daily basis from the date on which such sum fell due to the date of payment.

TIME AND FORCE MAJEURE

- (i). Any time for delivery stated by the Company is an estimate only. Although the Company will use its best endeavours to supply the Goods and make deliveries in accordance with any time stipulation contained in the Contract, time is not of the essence of the Contract. If the company for whatever reason is unable to supply the Goods or make a delivery in accordance with the time stipulation, the Company is entitled to a reasonable extension of the time without entitling the Buyer to cancel the Contract and the Company shall not be liable for any loss or damage suffered by the Buyer by reason of any delay in supply or delivery.
- (ii). If the Company is prevented or hindered from supplying or making delivery of the Goods by reason of force majeure which expression shall be understood to include any abnormal or unforeseeable circumstances including, without any prejudice to the generality of the foregoing, strikes, lockouts or other labour disputes, war, fire, accident, shortage of materials or fuel, illness or epidemics or national government inference of any description whether or not imputable to the Company through which the fulfilment of any obligation on the part of the company is hindered interfered with wholly or in part and on the grounds of which such fulfilment cannot reasonably be expected, the Company may as its option at any time either cancel the Contract or suspend supply or delivery to the reasonable time after removal of the clause preventing or hindering the same.
- (iii). The Company expressly declares that if it relies for the performance of the Contract on the due performance of Contract with its manufacturers suppliers and sub-contractors a written declaration by the Company shall be accepted by the Buyer as conclusive proof of prevention or hindrance of supply and delivery.

DELIVERY

The Goods will be delivered by the company to the Buyer at the address specified in the Order confirmed by the Company in its Order of acknowledgement. Unless otherwise specifically agreed in writing between Company and the Buyer all costs and charges in respect of transport and delivery including insurance (if any), during transit shall be borne by the Buyer. Subject to written notice by the Buyer to the Company and the carrier as the case may be in accordance with clause hereof the Goods shall be deemed to have been delivered complete and in satisfactory condition.

RISK

- (i). If delivery of the Goods is under the Contract to be made within the United Kingdom the Goods will be at the Buyer's risk as from the time of delivery. In all other cases the risk in the Goods shall pass to the Buyer as from the time when the Goods have been delivered by the company to a carrier for transmission to or at the direction of the Buyer.
- (ii). Where the Goods remain at the risk of the Company after dispatch the Buyer is liable to the Company for all loss and damage caused by failure of the Buyer to do anything necessary to enable the Company to pursue any claim which the Company may have against the carrier.
- (iii). It is the sole responsibility of the Buyer to ensure that on arrival of their destination the Goods are expeditiously and safely unloaded. The Company is not liable for any damage to Goods caused during unloading or for any other loss or damage occasioned thereby.

PASSING OF PROPERTY

- (i). The title to beneficial ownership of the Goods shall not pass to the Buyer but remain in the Company until full payment has been received by the Company.
- (ii). The Buyer shall not re-sell or incorporate into another product or thing any of the Goods which have not been paid for but shall keep and store such unpaid Goods identified as belonging to the Company and separate from any other Goods, product or thing.
- (iii). If contrary to sub-clause 2 hereof any unpaid for Goods are re-sold by the Buyer, the Buyer shall be deemed to have made such re-sale as agent for the Company and in fiduciary capacity and the company shall be entitled to the proceeds thereof or to any claim the Buyer may have arising out of such re-sale.

company shall be entitled to the proceeds thereof or to any claim the Buyer may have arising out of such re-sale.

- (iv). If contrary to sub-clause 2 hereof any unpaid Goods are incorporated into another product or thing such new product or thing shall be the sole property of the Company and be kept and stored at the Buyer's risk by the Buyer identified as belonging to the Company and separate from any other Goods, products or thing but nevertheless so that if contrary to this sub-clause the Buyer sells such new product or thing the Buyer shall be deemed to have made such sale as agent for the Company and in a fiduciary capacity and the Company shall be entitled to the proceeds thereof or to any claim that the Buyer may have arising out of such sale to the extent of the amount due to the Company as payment for the Goods so incorporated.
- (v). While any of the Goods remain unpaid for the Company shall be entitled to a demand that the buyer at the Buyer's own expense returns the Goods or any new product or thing into which they may have been incorporated to the Company but if the Buyer should refuse or fail within seven (7) days of such a demand to return the Goods or any such new product or thing as the case may be the Company is irrevocably authorised by the Buyer without notice to enter into the premises of the Buyer and remove the Goods or such new product or thing as the case may be.

WARRANTY AND SUITABILITY

- (i). Goods are sold with the express understanding that the Buyer will independently determine the suitability of the Goods for the purpose for which they are supplied. All drawings, illustrations or specifications accompanying a Quotation or contained in any price list or catalogue are to be treated as explanatory only and do not form part of the Contract. Performance capacity, suitability, recommendations, descriptions or other particulars concerning the Goods stated

and

given by the Company in good faith as being approximately correct but in particular having regard to the extremely wide variety of conditions prevailing in the fact that the Company may not itself be the manufacturer of the Goods. It is the responsibility of the Buyer to ensure that the Goods are adequate for the purpose intended and to have tested the suitability of the

Goods

for the particular use contemplated. The Company is not responsible for any loss direct or consequential caused by reason of the Goods though supplied in accordance with the Order not being fit for purpose or use.

- (ii). The Company warrants the goods will operate in the manner set out in the Quotation referred to above and the materials and workmanship in the product conform to the best commercial practice.

CLAIMS BY THE BUYER

It shall be the duty of the Buyer to ensure inspection of the Goods upon delivery. The Company shall not be liable for any claim whatsoever by the Buyer howsoever arising (including any claim arising by reason of the negligence of the Company or its servants or agents), in respect of a defect in quality or quantity of the Goods or for any loss or damage in transit less notice is given to the Company and the carrier as the case may be within six (6) hours of delivery. In the event of the Buyer submitting a claim the Buyer will at his own expense return the Goods subject of the claim to the Company within seven (7) days of notifying the complaint.

LIABILITY

- (i). Subject and without prejudice to Clause 10 hereof the Company's liability in respect of any claim made by the Buyer is limited solely to the replacement or repair of the Goods not delivered, damaged in transit or otherwise defective as the case may be or, at the option of the Company the value thereof and shall, (subject to sub-clause (iii) hereof) in no event extend to any liability for loss of profit or damage to plant or for any costs incurred by the Buyer in repairing or doing work on the Goods (unless such repairs or work is effected by or on behalf of the Buyer with the prior written consent of the Company), or for consequential or special loss or damage sustained by the Buyer arising out of such non delivery, damage in transit or defect.
- (ii). In the event of any liability or loss, direct or consequential, caused or suffered by the Buyer in consequence of any defect in the Goods such defect being caused by any manufacturer supplier or subcontractor to the Company, the Company shall be under no liability in respect thereof

save

- as provided in sub-clause (i) hereof but shall, upon written request of the Buyer, assign to the Buyer such rights as it has against such manufacturer supplier or sub-contractor and to do all such acts as may be reasonably necessary to enable the Buyer to pursue any claim against such manufacturer, supplier or sub-contractor provided always that the Buyer keeps the Company at all times fully indemnified in respect of the cost thereof.
- (iii). Subject as herein provided all warranties, guarantees, conditions and representations on the part of or to be performed by the Company whether collateral hereto or otherwise and whether express or implied by common law, statute, custom of the trade, or otherwise are hereby expressly excluded and extinguished so far as the law applicable hereto will allow.
- (iv). The Buyer shall indemnify the Company in the event of any claim against the Company by reason of any loss, damage or injury occasioned by the Goods after delivery or arising out of the use of the Goods by the Buyer or others.

BUYERS' OBLIGATION AND DEFAULT

- (i). Once a Contract subsists between the Company and Buyer the same cannot be cancelled by the Buyer except with the Company's written consent and on terms which will indemnify the Company against all losses and costs occasioned by such cancellation.
- (ii). No Goods whether or not claimed by the Buyer and/or acknowledgement by the Company to be defective, will be accepted if returned unless such return is authorised by the Company.
- (iii). If the Buyer fails to accept delivery of or to make payment for the Goods, commits any act of bankruptcy or becomes insolvent or has any execution or distress levied upon his Goods or property being a limited Company passes any resolution for its winding up Order for winding up is made or if a receiver is appointed or if any time the Company reasonably considers that the Buyer is or may be unable to pay for the Goods to be delivered in accordance with the Contract the Company may stop any of the Goods in transit and suspend further deliveries and may determine the Contract but nothing in this clause shall prejudice any existing claims or any other right vested in the Company.

CONSTRUCTION AND PROPER LAW

The Contract shall be constructed in accordance with and governed by the law of England which will be the proper law of the Contract and the Buyer agrees to submit the exclusive jurisdiction of the English Courts.

SITE CONDITIONS

- (i). All dimensions submitted by the Buyer for the Goods to be supplied to him shall be the sole responsibility of the Buyer.
- (ii). In all circumstances where the Buyer submits measurements he must clearly state whether these are for the actual Goods or for the location into which he intends to fit the Goods.
- (iii). Where the Company is fitting the Goods on site, the customer shall make provision for reasonable working conditions including an electrical power supply in the proximity of work to be carried out, such scaffolding or staging as may be necessary, secure storage space, parking, unloading and hoisting facilities and these to be provided free of charge.
- (iv). The Buyer shall take full responsibility for any defect in prepared surfaces and site conditions except in those circumstances where the Company is carrying out alterations to such prepared services and site conditions.

