

MicroLouvre

Product Testing

Resistance to Wind Load Test Report Summary

Product:
MicroLouvre K700-17

Coating:
Interpon 610 – RAL 1033
Poly Powder Coating (PPC)

MicroLouvre

Product Testing

TABLE OF CONTENTS

	SECTION	PAGE
1	Summary	3
2	Test Method / Procedure	3
2.1	Construction	4
3	Conclusions	5
4	Calculations	5
5	Data Sheets	6

MicroLouvre

Product Testing

1 Summary

This report details the wind loading resistance evaluation completed for SmartLouvre's MicroLouvre (Koolshade – USA), to be referenced from here on as ML, conducted in house for indicative performance. The evaluation consists of subjecting the largest practicable ML screen to a deflection and theoretical positive pressures of _____ Pa. Test protocol was conducted at SmartLouvre according to EN 1932:2013 and classified in EN 13561:2015/AC. Although ML is not a compliant product for this test some assumptions were made to carry out the test (i.e. the fabric is fully obstructed allowing no wind to pass through).

The ML panel was constructed as specified in the test method to maximum listed build size and ML fabric were examined for damage and deflection through visual inspection, observed and recorded throughout the test.

2 Test Method / Procedure

The method followed listed in EN 1932:2013 § 5.3.

Test loads are obtained by using a mattress of 10 cm of thickness and adding the missing weight, distributed in a uniform way, over the mattress (see Figure 6).

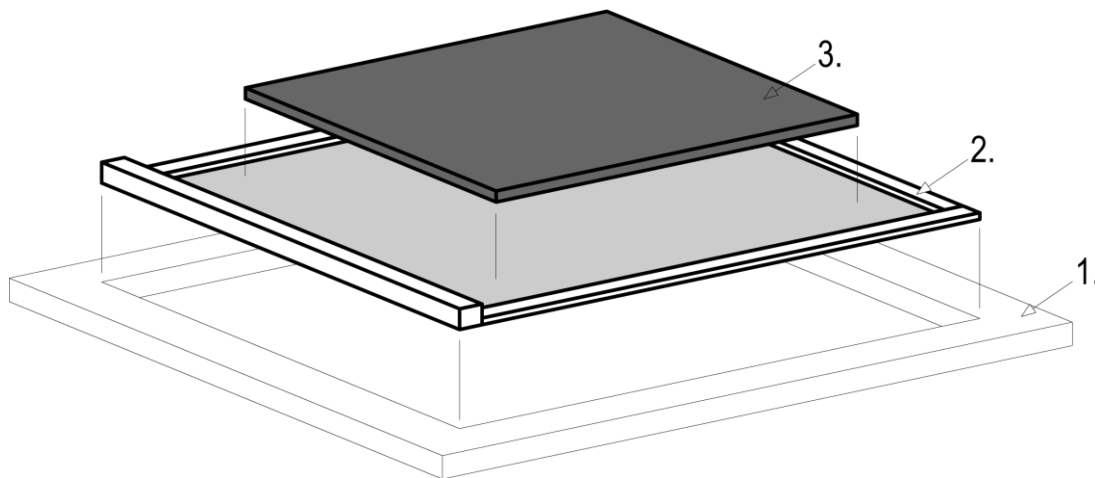

Key

- 1. rigid frame
- 2. awning
- 3. mattress

Figure 6 — Example of method of loading N°2 for a guided awning

The mattress width and height shall be 20 cm smaller than the width and the height of the visible part of the curtain in order to avoid blocks to the free movements of the curtain (see Figure 7).

The total weight applied shall be the test load reduced by the weight of the curtain. In the case the missing weight is applied of punctual loads, at least nine loads per m² shall be distributed at regular intervals on the mattress.

MicroLouvre

Product Testing

2.1 Construction

A 1.8m x 3m ML panel was constructed to nominal standards in 13mm x 50mm aluminium extrusion by SL(FE51). This panel was clamped to trestles about 1m from the floor in a horizontal plane. The mattress was placed in the centre of the test specimen and marked out to allow the correct placement of the weights.



MicroLouvre

Product Testing

3 Conclusions

The test was stopped when a sufficient distributed load (150kg of iron weights were used to simulate 1470N of pressure on the ML fabric) was applied to the test specimen.

Using the calculation of test loads in EN 13651:2015 the following conclusions can be made regarding nominal and safety load of ML fabric in a standard installation if the open area is completely obstructed.

The fabric deformed uniformly with a maximum distance of 300mm at the centre of the panel. There were no catastrophic failures of the panel construction or tears in the fabric.

The recommendation is that MicroLouvre K700-17 should be rated at **Class 5** wind resistance according to EN 13651:2015-AC

4 Calculations

Nominal load:

$$FN = \beta \times p_N \times L \times H$$

$$1 \times 272 \times 1.8 \times 3.0 = 1470p_N = 272N/m^2$$

Safety load:

$$FS = \gamma \times FN, \text{ with } \gamma = 1,2$$

$$1.2 \times 1470 = 1764p_N = 327N/m^2$$

- a) *L, H: respectively width and height of the test specimen as defined in Clause 3;*
- b) *p_N: threshold value of nominal test pressure in N/m² corresponding to the class considered (see EN 13561 for external blinds and awnings and EN 13659 for shutters);*
- c) *β: coefficient of conversion from distributed loads to test loads; it depends on the type of external blinds or awnings:*
 - 1) *β = 0,5 in the case of folding arm awning, treillis arm awning, projecting awning and marquiselette,*
 - 2) *β = 1 in the case of external blind with lateral guiderail with or without tension system;*
- d) *γ: coefficient of transition from the nominal loads to the safety loads.*

Classes of wind resistance	0	1	2	3	4	5	6
Nominal wind pressure p _N (N/m ²)	<40	40	70	110	170	270	400
Safety wind pressure p _N (N/m ²)	<48	48	84	132	204	324	480

MicroLouvre

Product Testing

5 Data Sheets

See the attached technical data sheets.

MicroLouvre™ Product Specification

FABRIC CONSTRUCTION

Open Area.....	80%
Thickness of fabric.....	1.5mm (0.06") nominal coated
Weight kg/m ²	1.1 kg/m ² (2.4lbs) nominal coated
Standard Widths	1872mm(73"), 1555mm(60"), 1250 (49")
Area of Fabric per Roll	38m ²
Maximum Cont. Length	30.4m(100)*
Standard Finish.....	80 - 100µm - Interpon A2202 MN204E Polyester- smooth, matt
Coating Durability.....	Meets / exceeds 1,000hrs ISO 9227, ISO 6270 & ASTM G154 QUVB 313B bulbs test
Composition.....	90% CuZn10 (C220) commercial bronze /10% CuSi3 (C655) silicon bronze
Fire Rating.....	Class A1 in accordance with BS EN 13501-1:2002
Fire Attenuation.....	49.4% Compliant screening for bushfire up to BAL-40 (Results based on 40kW/m2 incident irradiance.)
Applications.....	Solar Shading, Lighting Solutions, Glass Lamination Heat Attenuation, Privacy & Security

*Longer roll lengths on application

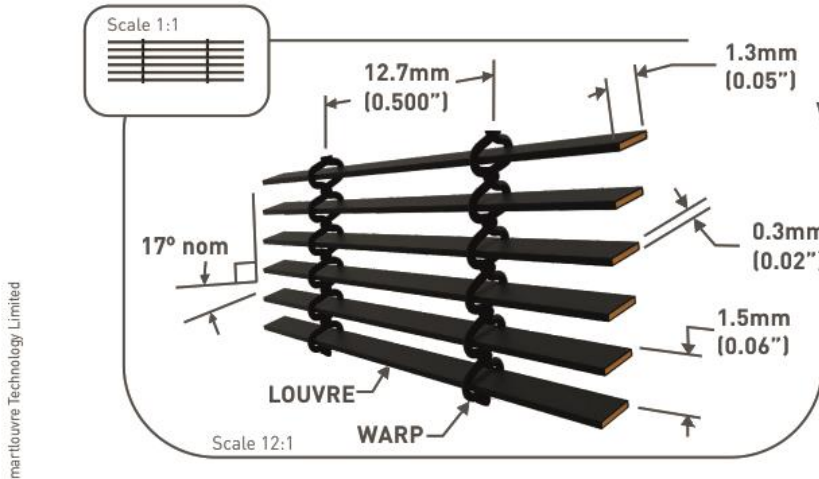

smartlouvre Technology Limited



18 The Tanneries, Brockhampton Lane,
Havant, Hants, PO9 1JB, United Kingdom

T: +44 (0) 23 9245 6333
E: sales@smartlouvre.com



05/07/18

2

MF-FC-01/2

MicroLouvre

Product Testing



Drawing on Innovation
CENTRAL WIRE INDUSTRIES

Copper C220

Chemistry Specifications:

CU: 89-91% Zn: Rem Pb: .05% max Fe: .05% max

Mechanical Properties:

	Tensile	Yield	Elongation
Soft:	35-45 Ksi	15-25 Ksi	25% min
1/8 HD:	38-48 Ksi	18-25 Ksi	20% min
1/4HD:	45-57 Ksi	N/A	1% min
1/2HD:	56-67 Ksi	N/A	1% min
3/4HD:	64-74 Ksi	N/A	1% min
Full HD:	78-86 Ksi	N/A	1% min
Spring:	84 min Ksi	N/A	1% min

Density: .318(lb/in³)

Resistivity: 23.6 Ohms.cmil/ft

Resistance Specifications:

Industrial Standards followed unless specified by customer for special resistance.

15ga (.057") to 23ga (.0225) +/-3%

24ga (.0201 to 36ga (.005) +/-5%

37ga (.0044) to 42ga (.0025) +/-8%

Note: Diameter is governed by resistance unless specified by the customer.

Material annealing temperature for soft and 1/8HD material is 1100-1150 degrees Fahrenheit (593.3-621.1C).

.0226" (23ga) and larger diameter +/--.0005"

.0126" (28ga) to .0201" (24ga) +/--.0003"

.0025" (42ga) to .0113" (29 ga) +/--.0002"

MicroLouvre

Product Testing



Gage AWG	Diameter Inch	Nominal Resistance	Weight lb/1000 ft
15	.057"	.00726 ohms/ft	9.74 lb/1000 ft
16	.0508"	.00914 ohms/ft	7.73 lb/1000 ft
17	.045"	.01165 ohms/ft	6.07 lb/1000 ft
18	.0403"	.01453 ohms/ft	4.87 lb/1000 ft
19	.036"	.01821 ohms/ft	3.88 lb/1000 ft
20	.032"	.02305 ohms/ft	3.07 lb/1000 ft
21	.0285"	.02906 ohms/ft	2.43 lb/1000 ft
22	.0253"	.03687 ohms/ft	1.92 lb/1000 ft
23	.0226"	.04621 ohms/ft	1.53lb/1000 ft
24	.0201"	.05841 ohms/ft	1.21 lb/1000 ft
25	.0179"	.07366 ohms/ft	0.96 lb/1000 ft
26	.0159"	.09335 ohms/ft	0.76 lb/1000 ft
27	.0142"	.11704 ohms/ft	0.60 lb/1000 ft
28	.0126"	.14865 ohms/ft	0.48 lb/1000 ft
29	.0113"	.18482 ohms/ft	0.38 lb/1000 ft
30	.010"	.23600 ohms/ft	0.30 lb/1000 ft
31	.009"	.29135 ohms/ft	0.24 lb/1000 ft
32	.008"	.36875 ohms/ft	0.19 lb/1000 ft
33	.007"	.48163 ohms/ft	0.15 lb/1000 ft
34	.0063"	.59460 ohms/ft	0.12 lb/1000 ft
35	.0056"	.75255 ohms/ft	0.09 lb/1000 ft
36	.005"	.94400 ohms/ft	0.07 lb/1000 ft
37	.0045"	1.1654 ohms/ft	0.06 lb/1000 ft
38	.004"	1.4750 ohms/ft	0.05 lb/1000 ft
39	.0035"	1.9265 ohms/ft	0.04 lb/1000 ft
40	.0031"	2.4558 ohms/ft	0.03 lb/1000 ft

MicroLouvre

Product Testing



Drawing on Innovation
CENTRAL WIRE INDUSTRIES

Copper C655

Chemistry Specifications:

CU: Rem Zn: 1.5%max P: .2- .3% Pb: .05% max Fe: .80% max Mn: .5 – 1.30%
Si: 2.80 – 3.80% Ni+Co: .60% max

Mechanical Properties:

	Tensile	Yield	Elongation
Soft:	55-65 Ksi	25-35 Ksi	40% min
1/8 HD:	65-75 Ksi	N/A Ksi	1% min
1/4HD:	75-85 Ksi	N/A Ksi	1% min
1/2HD:	93-103 Ksi	N/A Ksi	1% min
3/4HD:	105-115 Ksi	N/A	1% min
Full HD:	120-130 Ksi	N/A	1% min
Spring:	140-150 Ksi	N/A	1% min
Density:	.308(lb/in ³)	Resistivity: 148 Ohms.cmil/ft	

Resistance Specifications:

Industrial Standards followed unless specified by customer for special resistance.

15ga (.057") to 23ga (.0225) +/-3%
24ga (.0201 to 36ga (.005) +/-5%
37ga (.0044) to 42ga (.0025) +/-8%

Note: Diameter is governed by resistance unless specified by the customer.

Material annealing temperature for soft and 1/8HD material is 1200-1250 degrees Fahrenheit (648.8- 676.6C).

.0226" (23ga) and larger diameter +/--.0005"
.0126" (28ga) to .0201" (24ga) +/--.0003"
.0025" (42ga) to .0113" (29 ga) +/--.0002"

MicroLouvre

Product Testing



Drawing on Innovation
CENTRAL WIRE INDUSTRIES

Alloy Data:

Gage AWG	Diameter Inch	Nominal Resistance	Weight lb/1000 ft
18	.0403"	.091128 ohms/ft	4.71 lb/1000 ft
19	.036"	.11420 ohms/ft	3.76 lb/1000 ft
20	.032"	.14453 ohms/ft	2.97 lb/1000 ft
21	.0285"	.18221 ohms/ft	2.36 lb/1000 ft
22	.0253"	.23122 ohms/ft	1.86 lb/1000 ft
23	.0226"	.28976 ohms/ft	1.48 lb/1000 ft
24	.0201"	.36633 ohms/ft	1.17 lb/1000 ft
25	.0179"	.46190 ohms/ft	0.93 lb/1000 ft
26	.0159"	.58542 ohms/ft	0.73 lb/1000 ft
27	.0142"	.73398 ohms/ft	0.59 lb/1000 ft
28	.0126"	.93222 ohms/ft	0.46 lb/1000 ft
29	.0113"	1.1591 ohms/ft	0.37 lb/1000 ft
30	.010"	1.4800 ohms/ft	0.29 lb/1000 ft
31	.009"	1.8271 ohms/ft	0.24 lb/1000 ft
32	.008"	2.3125 ohms/ft	0.19 lb/1000 ft
33	.007"	3.0204 ohms/ft	0.14 lb/1000 ft
34	.0063"	3.7289 ohms/ft	0.12 lb/1000 ft
35	.0056"	4.7194 ohms/ft	0.09 lb/1000 ft
36	.005"	5.9200 ohms/ft	0.07 lb/1000 ft
37	.0045"	7.3086 ohms/ft	0.06 lb/1000 ft
38	.004"	9.2500 ohms/ft	0.05 lb/1000 ft
39	.0035"	12.0816 ohms/ft	0.04 lb/1000 ft
40	.0031"	15.4006 ohms/ft	0.03 lb/1000 ft