

Tensile Performance Test Report Summary

**Product:
MicroLouvre K700-17**

**Coating:
Interpon 610 – RAL 1033
Poly Powder Coating (PPC)**

MicroLouvre

Product Testing

TABLE OF CONTENTS

	SECTION	PAGE
1	Summary	3
2	Test Method / Procedure	3
3	Conclusions	10
4	Data Sheets	11-15

MicroLouvre

Product Testing

1 Summary

In order to find the uniaxial stress safety factor of MicroLouvre (Koolshade – USA) in tension, a test was devised to stress a 1m² panel under load in as typical and installation as possible.

2 Test Method / Procedure

The piece of ML fabric was installed using a 3-louvre lace in our standard FE51 frame. The upper extrusion was attached at multiple points to the upper frame to prevent deflection. A single length of Unistrut was mounted to the lower extrusion to provide a means to mount the weights.

The load was applied symmetrically, 5kg at a time, examining the system at each interval to check for signs of stretching or fatigue.

The specification from Central Wire has listed the yield of C655 (warp wire) at 25–35ksi or 172 – 241MPa.

MicroLouvre

Product Testing



MicroLouvre

Product Testing



MicroLouvre

Product Testing



MicroLouvre

Product Testing



MicroLouvre

Product Testing



MicroLouvre

Product Testing

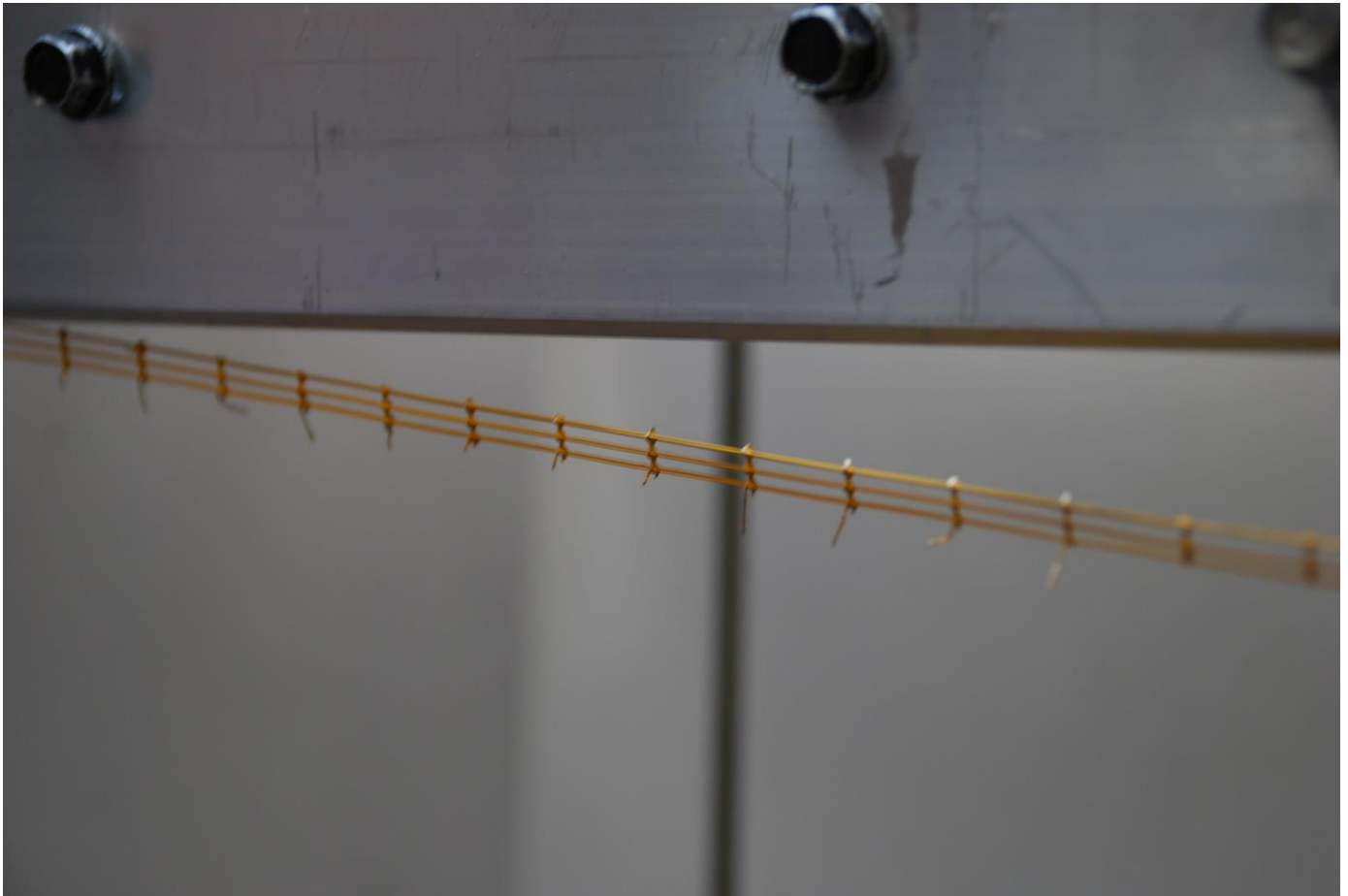

MicroLouvre

Product Testing

3 Conclusions

Test loading was maxed out at 150kg. Failure was forced around 170-175kg.

The warps failed near the upper extrusion where the no.3 louvre was holding the fabric in place. The failure was catastrophic and occurred <1 second.

The results are calculated below.

36.43 kilogram-force/millimeter² = 357.26 megapascal = 51.82 ksi (51,820 pound-force/inch²)

(For reference: A single strand of C655 wire at 0.254mm (.010") will yield at somewhere ~1.8kg of load.)

It is recommended that any installation of tensioned ML fabric not exceed 25kgf/m².

4 Data Sheets

See the attached technical data sheets.

MicroLouvre

Product Testing

MicroLouvre™ Product Specification

FABRIC CONSTRUCTION

Open Area.....	80%
Thickness of fabric.....	1.5mm (0.06") nominal coated
Weight kg/m ²	1.1 kg/m ² (2.4lbs) nominal coated
Standard Widths	1872mm(73"), 1555mm(60"), 1250 (49")
Area of Fabric per Roll	38m ²
Maximum Cont. Length	30.4m(100')*
Standard Finish.....	80 - 100µm - Interpon A2202 MN204E Polyester- smooth, matt
Coating Durability.....	Meets / exceeds 1,000hrs ISO 9227, ISO 6270 & ASTM G154 QUVB 313B bulbs test
Composition.....	90% CuZn10 (C220) commercial bronze /10% CuSi3 (C655) silicon bronze
Fire Rating.....	Class A1 in accordance with BS EN 13501-1:2002
Fire Attenuation.....	49.4% Compliant screening for bushfire up to BAL-40 (Results based on 40kW/m ² incident irradiance.)
Applications.....	Solar Shading, Lighting Solutions, Glass Lamination Heat Attenuation, Privacy & Security

*Longer roll lengths on application

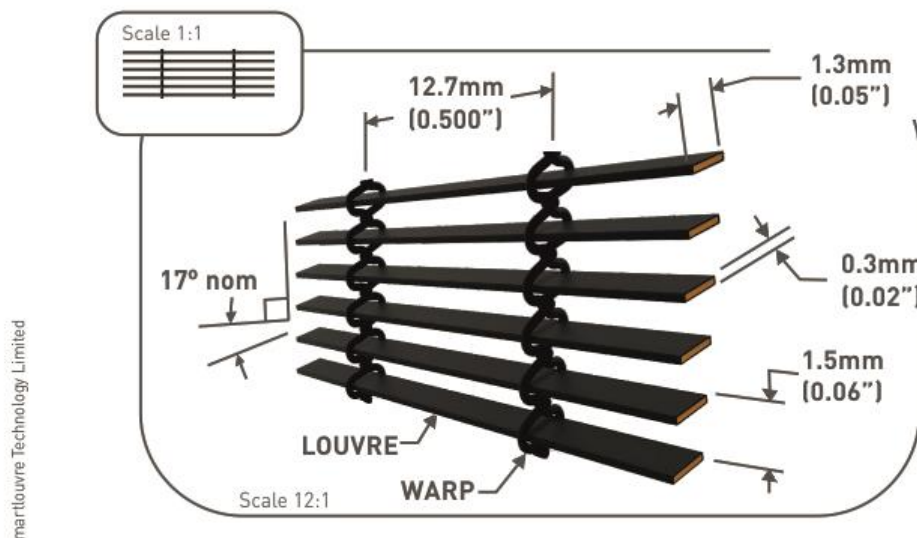

18 The Tanneries, Brockhampton Lane,
Havant, Hants, PO9 1JB, United Kingdom

T: +44 (0) 23 9245 6333
E: sales@smartlouvre.com



05/07/18

2

MF-FC-01/2

05/10/18

11

MF-TR-03

MicroLouvre

Product Testing



Drawing on Innovation
CENTRAL WIRE INDUSTRIES

Copper C220

Chemistry Specifications:

CU: 89-91% Zn: Rem Pb: .05% max Fe: .05% max

Mechanical Properties:

	Tensile	Yield	Elongation
Soft:	35-45 Ksi	15-25 Ksi	25% min
1/8 HD:	38-48 Ksi	18-25 Ksi	20% min
1/4HD:	45-57 Ksi	N/A	1% min
1/2HD:	56-67 Ksi	N/A	1% min
3/4HD:	64-74 Ksi	N/A	1% min
Full HD:	78-86 Ksi	N/A	1% min
Spring:	84 min Ksi	N/A	1% min

Density: .318(lb/in³)

Resistivity: 23.6 Ohms.cmil/ft

Resistance Specifications:

Industrial Standards followed unless specified by customer for special resistance.

15ga (.057") to 23ga (.0225) +/-3%

24ga (.0201 to 36ga (.005) +/-5%

37ga (.0044) to 42ga (.0025) +/-8%

Note: Diameter is governed by resistance unless specified by the customer.

Material annealing temperature for soft and 1/8HD material is 1100-1150 degrees Fahrenheit (593.3-621.1C).

.0226" (23ga) and larger diameter +/--.0005"

.0126" (28ga) to .0201" (24ga) +/--.0003"

.0025" (42ga) to .0113" (29 ga) +/--.0002"

MicroLouvre

Product Testing



Gage AWG	Diameter Inch	Nominal Resistance	Weight lb/1000 ft
15	.057"	.00726 ohms/ft	9.74 lb/1000 ft
16	.0508"	.00914 ohms/ft	7.73 lb/1000 ft
17	.045"	.01165 ohms/ft	6.07 lb/1000 ft
18	.0403"	.01453 ohms/ft	4.87 lb/1000 ft
19	.036"	.01821 ohms/ft	3.88 lb/1000 ft
20	.032"	.02305 ohms/ft	3.07 lb/1000 ft
21	.0285"	.02906 ohms/ft	2.43 lb/1000 ft
22	.0253"	.03687 ohms/ft	1.92 lb/1000 ft
23	.0226"	.04621 ohms/ft	1.53lb/1000 ft
24	.0201"	.05841 ohms/ft	1.21 lb/1000 ft
25	.0179"	.07366 ohms/ft	0.96 lb/1000 ft
26	.0159"	.09335 ohms/ft	0.76 lb/1000 ft
27	.0142"	.11704 ohms/ft	0.60 lb/1000 ft
28	.0126"	.14865 ohms/ft	0.48 lb/1000 ft
29	.0113"	.18482 ohms/ft	0.38 lb/1000 ft
30	.010"	.23600 ohms/ft	0.30 lb/1000 ft
31	.009"	.29135 ohms/ft	0.24 lb/1000 ft
32	.008"	.36875 ohms/ft	0.19 lb/1000 ft
33	.007"	.48163 ohms/ft	0.15 lb/1000 ft
34	.0063"	.59460 ohms/ft	0.12 lb/1000 ft
35	.0056"	.75255 ohms/ft	0.09 lb/1000 ft
36	.005"	.94400 ohms/ft	0.07 lb/1000 ft
37	.0045"	1.1654 ohms/ft	0.06 lb/1000 ft
38	.004"	1.4750 ohms/ft	0.05 lb/1000 ft
39	.0035"	1.9265 ohms/ft	0.04 lb/1000 ft
40	.0031"	2.4558 ohms/ft	0.03 lb/1000 ft

MicroLouvre

Product Testing



Drawing on Innovation
CENTRAL WIRE INDUSTRIES

Copper C655

Chemistry Specifications:

CU: Rem Zn: 1.5%max P: .2- .3% Pb: .05% max Fe: .80% max Mn: .5 – 1.30%
Si: 2.80 – 3.80% Ni+Co: .60% max

Mechanical Properties:

	Tensile	Yield	Elongation
Soft:	55-65 Ksi	25-35 Ksi	40% min
1/8 HD:	65-75 Ksi	N/A Ksi	1% min
1/4HD:	75-85 Ksi	N/A Ksi	1% min
1/2HD:	93-103 Ksi	N/A Ksi	1% min
3/4HD:	105-115 Ksi	N/A	1% min
Full HD:	120-130 Ksi	N/A	1% min
Spring:	140-150 Ksi	N/A	1% min
Density:	.308(lb/in ³)	Resistivity: 148 Ohms.cmil/ft	

Resistance Specifications:

Industrial Standards followed unless specified by customer for special resistance.

15ga (.057") to 23ga (.0225) +/--3%
24ga (.0201 to 36ga (.005) +/--5%
37ga (.0044) to 42ga (.0025) +/--8%

Note: Diameter is governed by resistance unless specified by the customer.

Material annealing temperature for soft and 1/8HD material is 1200-1250 degrees Fahrenheit (648.8- 676.6C).

.0226" (23ga) and larger diameter +/--.0005"
.0126" (28ga) to .0201" (24ga) +/--.0003"
.0025" (42ga) to .0113" (29 ga) +/--.0002"

MicroLouvre

Product Testing



Drawing on Innovation
CENTRAL WIRE INDUSTRIES

Alloy Data:

Gage AWG	Diameter Inch	Nominal Resistance	Weight lb/1000 ft
18	.0403"	.091128 ohms/ft	4.71 lb/1000 ft
19	.036"	.11420 ohms/ft	3.76 lb/1000 ft
20	.032"	.14453 ohms/ft	2.97 lb/1000 ft
21	.0285"	.18221 ohms/ft	2.36 lb/1000 ft
22	.0253"	.23122 ohms/ft	1.86 lb/1000 ft
23	.0226"	.28976 ohms/ft	1.48 lb/1000 ft
24	.0201"	.36633 ohms/ft	1.17 lb/1000 ft
25	.0179"	.46190 ohms/ft	0.93 lb/1000 ft
26	.0159"	.58542 ohms/ft	0.73 lb/1000 ft
27	.0142"	.73398 ohms/ft	0.59 lb/1000 ft
28	.0126"	.93222 ohms/ft	0.46 lb/1000 ft
29	.0113"	1.1591 ohms/ft	0.37 lb/1000 ft
30	.010"	1.4800 ohms/ft	0.29 lb/1000 ft
31	.009"	1.8271 ohms/ft	0.24 lb/1000 ft
32	.008"	2.3125 ohms/ft	0.19 lb/1000 ft
33	.007"	3.0204 ohms/ft	0.14 lb/1000 ft
34	.0063"	3.7289 ohms/ft	0.12 lb/1000 ft
35	.0056"	4.7194 ohms/ft	0.09 lb/1000 ft
36	.005"	5.9200 ohms/ft	0.07 lb/1000 ft
37	.0045"	7.3086 ohms/ft	0.06 lb/1000 ft
38	.004"	9.2500 ohms/ft	0.05 lb/1000 ft
39	.0035"	12.0816 ohms/ft	0.04 lb/1000 ft
40	.0031"	15.4006 ohms/ft	0.03 lb/1000 ft