

TEST SUMMARY
Building Research Establishment
BRE FIRE & BUILDING TECHNOLOGY GROUP

High Speed Wind Integrity Test
MicroLouvre K700 / 17 Screens

TABLE OF CONTENTS

SECTION		PAGE
1	Introduction	3
2	Summary	3
3	Scope of Test	3
4	Description of Test Specimen(s)	4, 5
5	Test Methods	5, 6, 7
6	Test Evidence	7, 8
7	Conclusion	8

1 Introduction

A MicroLouvre™ K700-17 screen was tested for wind integrity at the outlet of the No3 Boundary Layer Wind Tunnel located at the Building Research Establishment (BRE) London on 8th December 2016.

The testing was intended to be progressive for

- 1) increasing wind speeds up to failure of the screen
- 2) 3 different screen angles to represent typical installations
- 3) 3 different wind direction on each of the screen angles

and finally

- 4) to maximise wind loading on the screen a polythene sheet was placed over the K700-17 metal fabric thereby stopping any passage of air.

2 Summary

The MicroLouvre™ K700-17 screen displayed no visible signs of damage after all tests in all orientations up to the maximum Wind Tunnel Speed possible of

102	miles per hour	mph
164	kilometres per hour	kph
46	metres per second	m/s
>12	Hurricane Force	Beaufort Scale
2	Category Hurricane	Saffir–Simpson scale

3 Scope of Test

As the MicroLouvre™ K700-17 screen is a unique product with 80% Open Area and 67% Openness Coefficient (Fraunhofer ISE) when fitted externally BRE were requested to test the production to destruction in multiple orientations as listed in Section 4 Test Methods. In addition as a final test of durability the open area of the screen fabric was fully covered, allowing zero permeability, to simulate the worst example of flying debris reducing the open area.

4 Description of Test Specimen

MicroLouvre

Test Summary

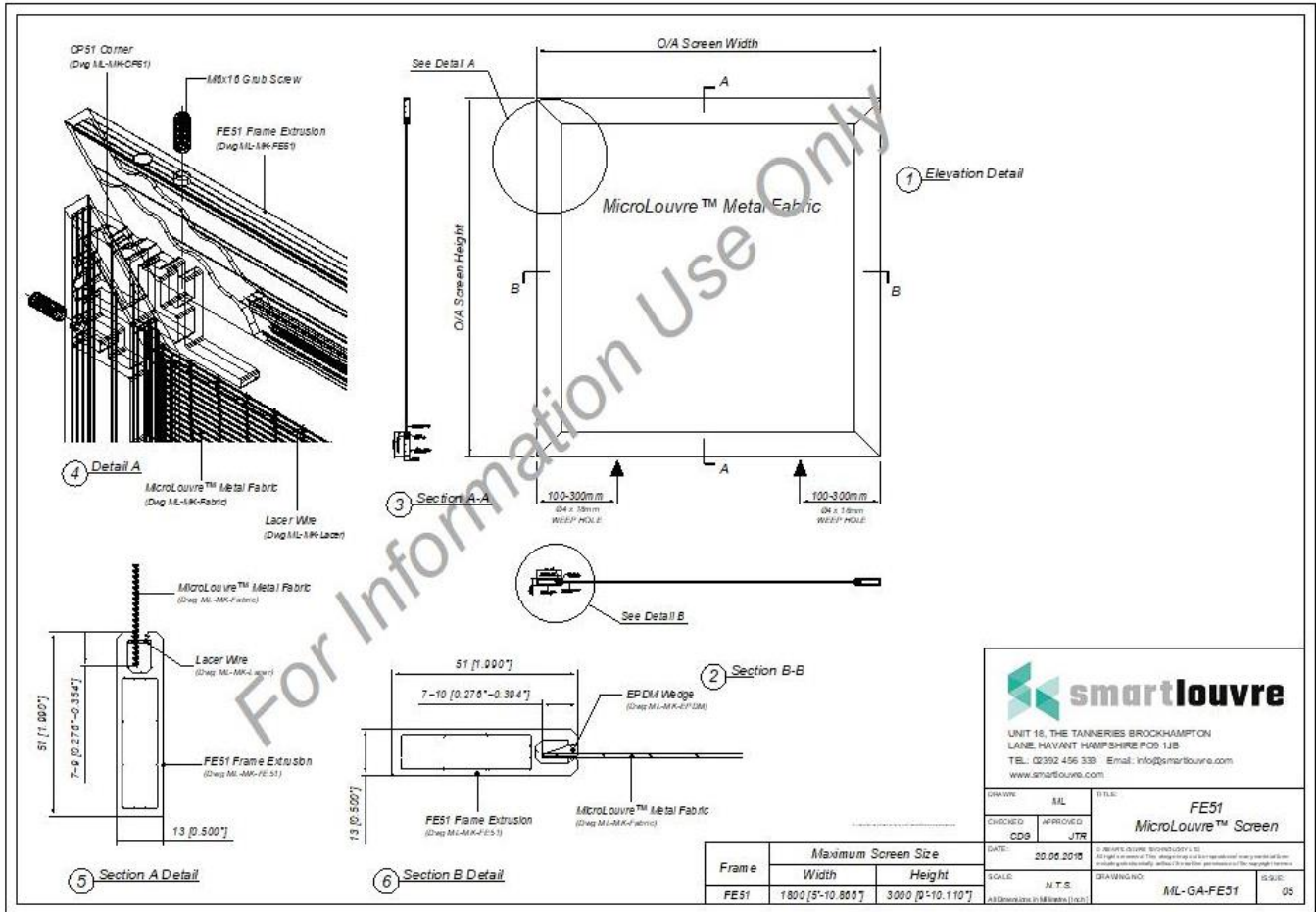

(Fig 1)

The 1000mm x 1000mm MicroLouvre™ K700-17 screen was fabricated (as Fig 1) from

- Metal Fabric Standard MicroLouvre K700-17
- Frame FE 51 extruded aluminium
- Corner Posts CP 51 machined aluminium corner posts
- Lacer Wire lateral tensioning system (top and bottom)
- EPDM Anti Vibration system (sides)

The frame was assembled and mounted in the test platform according to Fig: 2

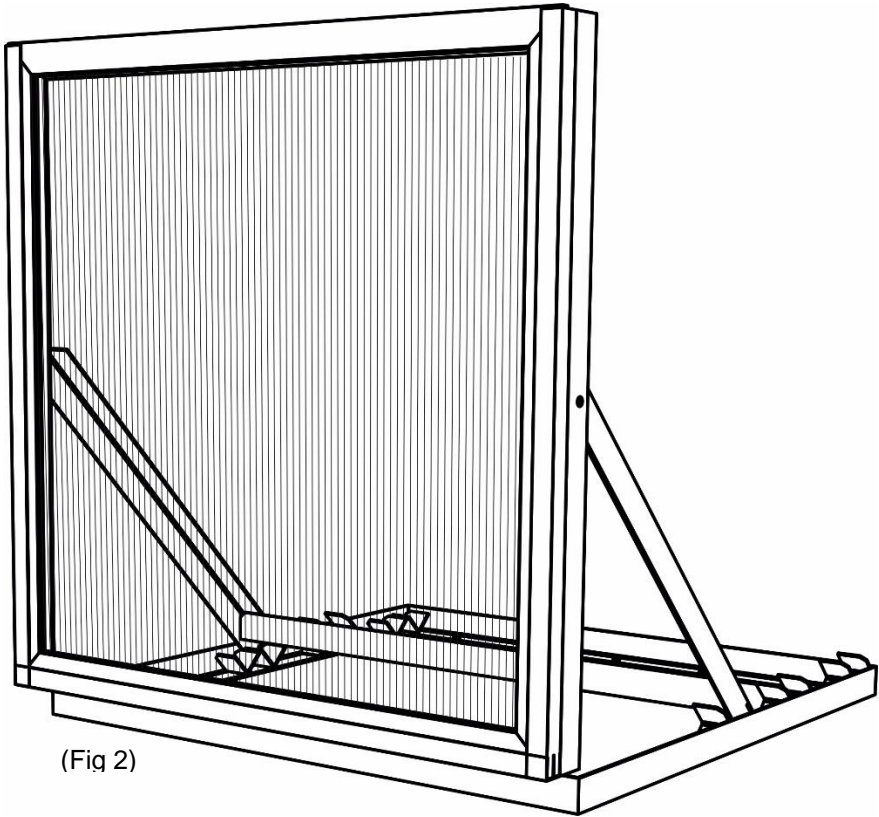

(Fig 2)

5 Test Methods

(i) Wind Direction

3 wind directions were tested (see Fig 3)

- i) 0° Azimuth angle
- ii) 45° Azimuth angle
- iii) 90° Azimuth angle

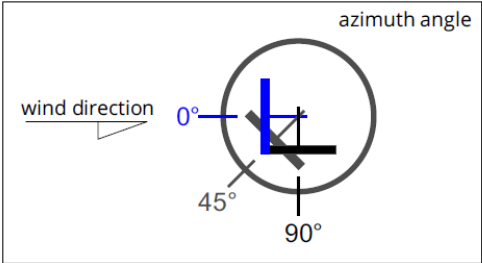

(Fig 3)

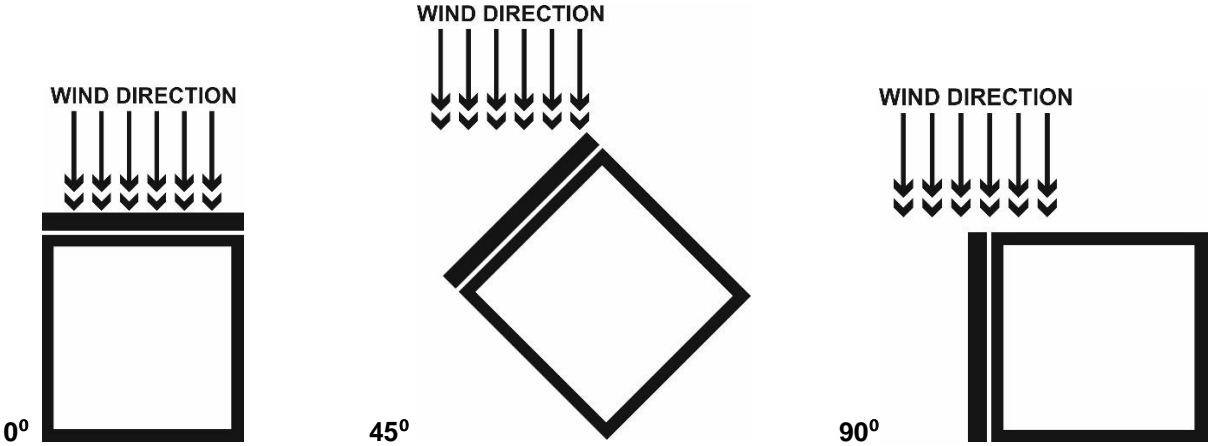

(Fig 3)

5 (ii) Louvre Orientation

2 louvre orientations were tested (see Fig 4)

- i) Normal
- ii) Reverse

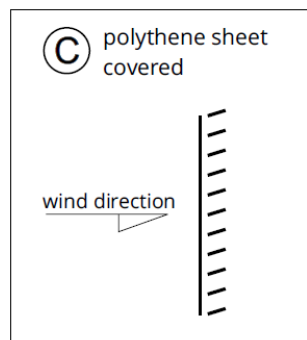
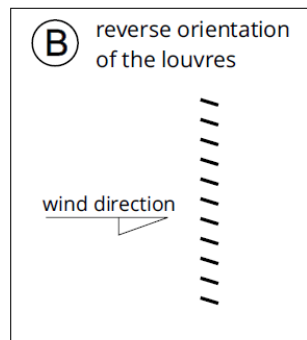
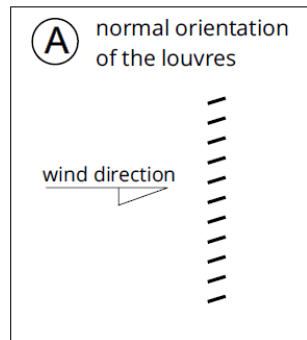

(Fig 4)

5 (iii) Screen Orientation

3 screen orientations were tested (see Fig 5)

- i) 90° Perpendicular / Vertical
- ii) 73° Inclined
- iii) 56° Inclined

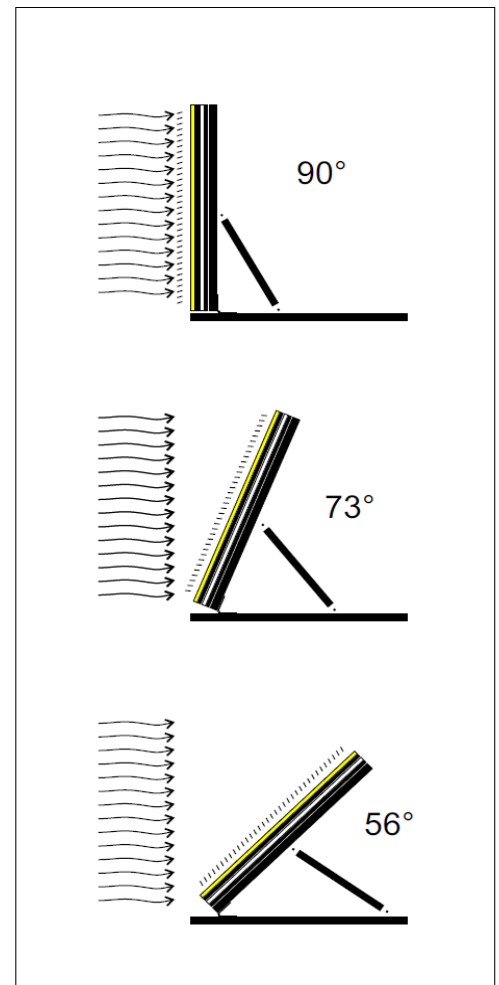

(Fig 5)

5 (iv) Wind Speeds

The MicroLouvre™ K700-17 screen was subjected to wind speeds from 5 m/s (11mph /18kph) to 46 m/s (102 mph / 166 kph) the maximum speed of the BRE Wind Tunnel (see Fig:6)

5 (v) Special Conditions

The MicroLouvre™ K700-17 screen area was covered in a polythene sheet to 100% cover the open area.

5 (vi) Test Parameter

To be tested to failure

MicroLouvre

Test Summary

Test Number	Screen Configuration	Wind Speeds (m/s)	Azimuth Angle	Pitch Angle
1	A	7, 17, 22, 45	0°	90°
2	A	10, 14, 17, 25, 36, 45	45°	90°
3	A	5, 22, 45	90°	90°
4	A	7, 13, 18, 38, 46	0°	73°
5	A	13, 17, 21, 35, 45	45°	73°
6	A	13, 27, 45	90°	73°
7	B	9, 10, 18, 24, 33, 45	0°	90°
8	B	7, 12, 16, 37, 45	45°	90°
9	B	22, 41, 45	90°	90°
10	B	8, 10, 26, 45	0°	73°
11	B	11, 17, 32, 45	45°	73°
12	B	16, 20, 41, 45	90°	73°
13	B	7, 24, 45	0°	56°
14	C	12, 45	0°	90°

(Fig 6)

6 Test Evidence

BRE FIRE & BUILDING TECHNOLOGY GROUP

CERTIFICATE OF TEST

This certificate verifies that a microlouvre™ solar control screen was tested for wind integrity at the outlet of the No3 Boundary Layer Wind Tunnel located at the Building Research Establishment (BRE) London on 8th December 2016.

A photograph of the microlouvre™ solar control screen mounted in the BRE wind tunnel (looking downstream) is shown below.



The testing was undertaken at speeds up to 45.4m/s (102mph). Three wind directions were tested, i.e. perpendicular to face, parallel to face, and at 45° to the face. The louvre face was fixed at angles of 90°, 73° and 56°, relative to horizontal. The full range of the tests undertaken is shown overleaf.

After the testing the test product was examined for signs of damage. No visible signs of damage were observed.

The testing was carried out and witnessed by Gordon Breeze and Dee Athwal from BRE, and witnessed by Carter Gilbert from Smartlouvre.

Signed.....

Principal Consultant, Fire & Building Technology Group

For and on behalf of BRE, Garston, Watford. WD25 9XX

BRE does not warrant the performance of this product and accepts no liability for any loss or damage arising from its use.

bre

Summary of High Speed Wind Tunnel Testing Undertaken at BRE

Test Number	Screen Configuration	Wind Speeds (m/s)	Azimuth Angle	Pitch Angle
1	A	7, 17, 22, 45	0°	90°
2	A	10, 14, 17, 25, 36, 45	45°	90°
3	A	5, 22, 45	90°	90°
4	A	7, 13, 18, 38, 46	0°	73°
5	A	13, 17, 21, 35, 45	45°	73°
6	A	13, 27, 45	90°	73°
7	B	9, 10, 18, 24, 33, 45	0°	90°
8	B	7, 12, 16, 37, 45	45°	90°
9	B	22, 41, 45	90°	90°
10	B	8, 10, 26, 45	0°	73°
11	B	11, 17, 32, 45	45°	73°
12	B	16, 20, 41, 45	90°	73°
13	B	7, 24, 45	0°	56°
14	C	12, 45	0°	90°

Legend:

Screen Configuration

- A is the orientation that the screen that would usually be installed on a building
- B is the inverted screen orientation
- C a polythene sheet was mounted over the screen

Azimuth Angle

The azimuth angle is the horizontal angle of the flow.

- An azimuth angle of 0° means that the approaching wind is perpendicular to the screen
- An azimuth angle of 90° means that the approaching wind is parallel to the screen

Pitch Angle

The pitch angle is the angle of the screen relative to horizontal.

- A pitch angle of 90° means that the screen is mounted perpendicular to the approaching wind
- A pitch angle of 0° means that the screen is mounted parallel to the approaching wind

bre

MicroLouvre

Test Summary



7 Conclusion

After the testing, the test product was examined for signs of damage.

No visible signs of damage were observed